

Draft

ANNEX

**Electronic Chart Display and Information System
for Inland Navigation**

(Inland ECDIS)

Edition 2.3

TABLE OF CONTENTS

SECTION 1: PERFORMANCE STANDARD FOR INLAND ECDIS	11
1. Introduction	11
2. Definitions	11
2.1 Terms	11
2.2 References	12
3. Contents, provision and updating of chart information	13
3.1 Contents and provision of Inland ENCs	13
3.2 Updates.....	14
4. Presentation of information.....	15
4.1 Display requirements	15
4.2 Display ranges (scales).....	15
4.3 Image positioning and orientation.....	15
4.4 Display of SENC information.....	15
4.5 Display of radar information.....	16
4.6 Display of other navigational information	17
4.7 Colours and symbols	17
4.8 Data and display accuracy.....	17
5. Operation.....	18
5.1 Information mode.....	18
5.2 Navigation mode	20
5.3 Operation and control elements	21
6. Connections with other equipment.....	22
7. Indications and alarms	22
7.1 <u>B</u> uilt in <u>T</u> est <u>E</u> quipment (BITE).....	22
7.2 Malfunctions	22
8. Fallback arrangements	22
8.1 Insufficient accuracy of the SENC-positioning	22
8.2 Defects	22
9. Power supply in navigation mode.....	22

SECTION 2: DATA STANDARD FOR INLAND ENCS.....	24
1. Introduction.....	24
2. Theoretical data model.....	24
3. Data structure	24
4. Product specification for Inland ENCs	24
5. Definitions.....	25
6. Procedures for changes of the appendices	25
SECTION 2A: CODES FOR PRODUCERS AND WATERWAYS (IN ADDITION TO IHO-S-62 ENC PRODUCER CODES)	26
SECTION 3: PRESENTATION STANDARD FOR INLAND ECDIS.....	30
1. Introduction.....	30
2. The Presentation Library for Inland ECDIS	30
2.1 Components of S-52 and Inland ECDIS Presentation Library	31
2.2 Look-up tables.....	31
2.3 Conditional symbology procedures (CS).....	32
2.4 Colours	32
2.5 Presentation of notice marks	33
3. Procedures for changes of the appendices	33
SECTION 4: OPERATIONAL AND PERFORMANCE REQUIREMENTS, METHODS OF TESTING AND REQUIRED TEST RESULTS	34
1. Introduction.....	34
1.1 Subject matter of this Section	34
1.2 Normative references	34
2. Operating modes and system configuration.....	35
2.1 Operating modes	35
2.2 System configurations.....	35
2.2.1 Inland ECDIS equipment, stand-alone-system without connection to radar	35
2.2.2 Inland ECDIS equipment, parallel installation and connection to radar.....	35
2.2.3 Inland ECDIS equipment, monitor shared with connected radar equipment.....	35
2.2.4 Radar equipment with integrated Inland ECDIS functionality	35
3. Performance requirements	36

3.1	Hardware performance	36
3.2	Software performance	36
3.3	Performance of operation controls	36
3.4	Display performance	36
3.4.1	Display dimensions	36
3.4.2	Display orientation	37
3.4.3	Display resolution	37
3.4.4	Display colours.....	37
3.4.5	Display brilliance	37
3.4.6	Picture renewal.....	37
3.4.7	Display technology	37
4.	Operational functions	37
4.1	Operating mode.....	37
4.2	Equipment pre-sets (store/recall)	38
4.3	Presentation of SENC information	38
4.4	Chart orientation, positioning and shifting.....	38
4.5	Position and bearing of the own ship	38
4.6	Information density	38
4.7	Ranges/Range rings.....	39
4.8	Picture brilliance	39
4.9	Picture colours.....	40
4.10	Pick report	40
4.11	Measuring features	40
4.12	Input and editing of skippers' own chart entries	40
4.13	Loading and updating of SENC's	40
4.14	Radar picture presentation and overlay	40
4.15	Inland ECDIS functions with immediate access.....	41
4.16	Permanently visible function parameters	42
5.	Service functions	42
5.1	Static correction of the chart position	42

5.2	Static correction of the chart orientation.....	42
5.3	Configuration of interfaces	42
6.	Hardware test and required certificates.....	43
6.1	Compatibility with the environmental requirements.....	43
6.2	Equipment documentation	43
6.3	Interfaces	43
6.4	Characteristic of operation controls	43
6.5	Characteristic of the display.....	43
7.	Test of the chart presentation, operation and functionality.....	43
7.1	Preparation of the Equipment Under Test (EUT)	43
7.2	Test of the operation modes	44
7.3	Test of the displayed features.....	44
7.4	Test of the scale dependent information density (SCAMIN).....	44
7.5	Test of brilliance variation	44
7.6	Test of the colours.....	44
7.7	Test of the measurement functions	45
7.8	Test of the chart update function.....	45
7.9	Test of displayed features in more than one cell of the same usage for the same area	45
8.	Test of radar picture presentation and operation.....	45
8.1	Preparations.....	45
8.2	Test of the radar picture without under laid chart.....	46
8.3	Test of the radar picture, overlaid information from other vessels and the underlying chart.....	46
8.3.1	Test of the radar overlay	46
8.3.2	Test of the chart positioning and orientation.....	47
8.3.3	Test of scale conformity.....	47
9.	Test of alarms and indications	47
10.	Test of fall back arrangements	48
SECTION 4A: MEASURES TO ENSURE SOFTWARE QUALITY		49
1.	General requirements	49
1.1	Software design requirements.....	49

1.2	Implementation requirements	49
1.3	Test requirements	50
1.4	Third party components requirements	50
1.5	Requirements for additional services in navigation mode	50
1.6	Language	50
1.7	Documentation requirements for users	50
2.	Methods of testing and required results	51
2.1	Navigation mode operation test	51
2.1.1	Performance requirements	51
2.1.1.1	Position.....	51
2.1.1.2	Heading	51
2.1.2	Sensor failure	51
2.1.3	Performance test interface.....	52
2.2	General software tests	53
2.2.1	Equipment documentation	53
2.2.2	Endurance test	53
3.	Changes to certified systems.....	54
3.1	General requirements	54
3.2	Hardware and software changes.....	54
SECTION 4B: SYSTEM CONFIGURATIONS (FIGURES)		55
SECTION 5: GLOSSARY OF TERMS		58
APPENDIX 1 PRODUCT SPECIFICATION FOR INLAND ENCS		
APPENDIX 1.1 INLAND ENC FEATURE CATALOGUE		
APPENDIX 1.2 INLAND ENC ENCODING GUIDE		
APPENDIX 2 PRESENTATION LIBRARY FOR INLAND ECDIS		

Structure of the technical specifications for Inland ECDIS

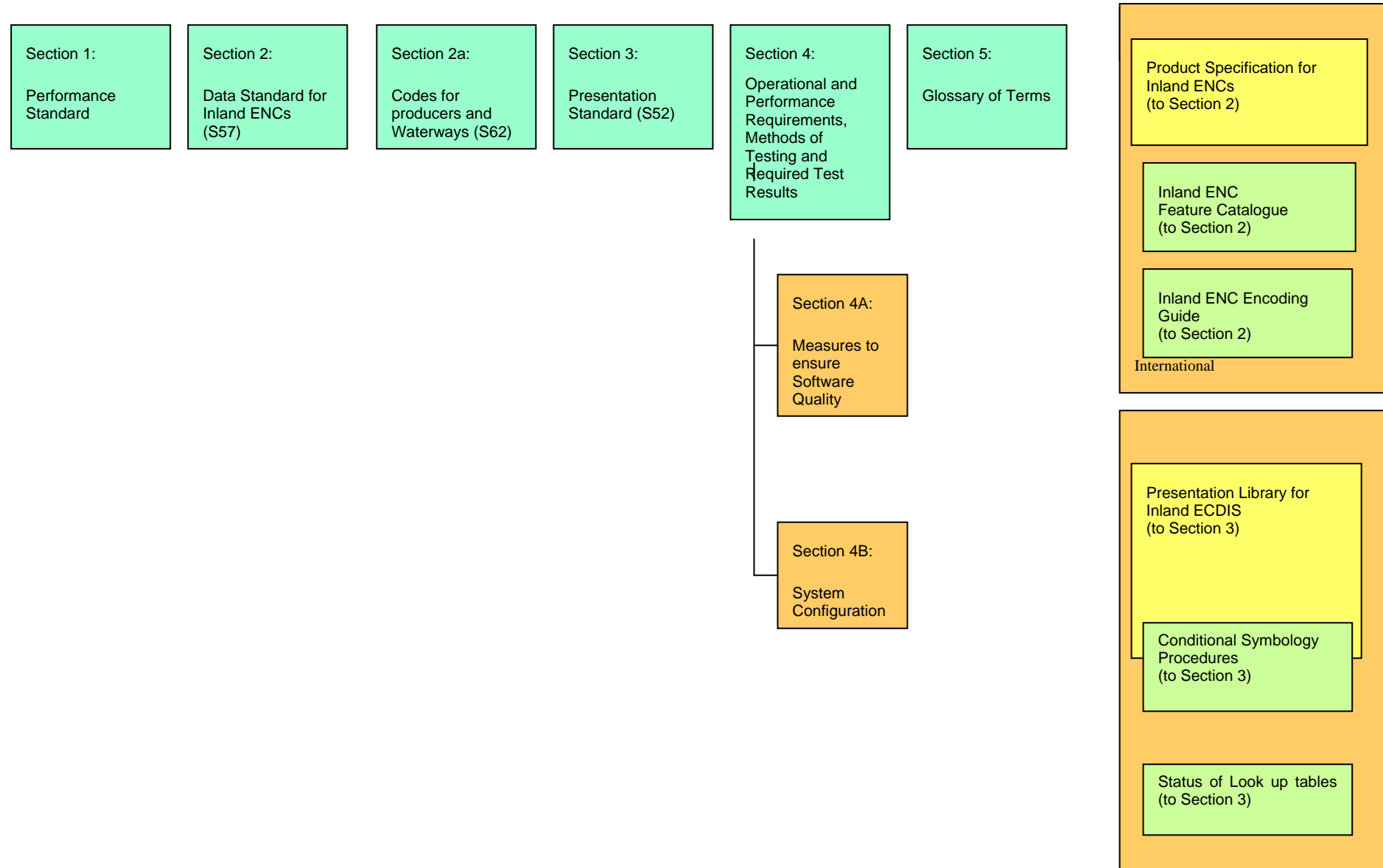

Comparison of the structures of the standard for (Maritime) ECDIS and of the technical specifications for Inland ECDIS

(Maritime) ECDIS	Inland ECDIS	OPEN ECDIS FORUM http://ienc.openecdis.org
<p>IMO A.817(19)MSC.232(82) revised Performance Standards for ECDIS, December 2006November 1995</p> <p>Appendix 1: Reference Documents Appendix 2: SENC Information available for display during route planning and route monitoring Appendix 3: Navigational Elements and Parameters Appendix 4: Areas for which special conditions exist Appendix 5: Alarms and Indicators Appendix 6: Back-up requirements Appendix 7: RCDS mode of operation</p>	Section 1: Performance Standard	
<p>IHO S-57: Transfer Standard for Digital Hydrographic Data, Edition 3.1, Supplement No. 2, June 2009November 2000</p> <p>Part 1: General Introduction Part 2: Theoretical Data Model Part 3: Data Structure</p> <p>Appendix A: IHO Object catalogue</p> <p>Introduction Chapter 1: Object Classes Chapter 2: Attributes Annex B: Attributes/Object Classes Cross Reference</p> <p>Appendix B: Product specifications</p> <p>Appendix B.1: ENC Product Specification Annex A: Use of The Object Catalogue for ENC Annex B: Example of CRC Coding</p> <p>Appendix B.2: IHO Object Catalogue Data Dictionary Product Specification</p>	Section 2: Data Standard for Inland ENC's	<p>Inland ENC Feature Catalogue</p> <p>Product Specification for Inland ENC's IENC Encoding Guide</p>
<p>IHO S-62 ENC Producer Codes, Edition 2.52, December 2009March 2006</p>	Section 2a: Codes for Producers and Waterways	<p>OEF (https://www.openecdis.org): Codes for Producers and Waterways (not part of the Inland ECDIS technical specifications)</p>

(Maritime) ECDIS	Inland ECDIS	OPEN ECDIS FORUM http://ienc.openecdis.org
<p>IHO S-52 Specification for Chart Content and Display Aspects of ECDIS, Edition 65, March 2010 December 1996</p> <p>Annex A: IHO ECDIS Presentation Library</p> <p>Annex B: Procedure for initial calibration of colour displays</p> <p>Annex C: Procedure for maintaining the calibration of displays</p> <p>Appendix 1: Guidance on Updating the Electronic Chart Annex A: Definitions and Acronyms Annex B: Current Updating Practice for Paper Charts Annex C: Estimate of Data Volume</p> <p>Appendix 2: Colour & Symbol Specifications for ECDIS Annex A: IHO ECDIS Presentation Library Part I: Use of the Presentation Library Part II: Mariners Navigational Objects Part III: Supplementary Features Annex B: Calibration of Colour CRTs Annex C: Maintaining the Calibration of Colour CRTs</p> <p>Appendix 3: Glossary of ECDIS Related Terms</p>	<p>Section 3: Presentation Standard</p>	<p>Presentation Library for Inland ECDIS</p> <p>Look-up Tables</p> <p>Symbols</p> <p>Conditional Symbology Procedures</p>
<p>IEC 61174, Edition 3.0: ECDIS - Operational and Performance Requirements, Methods of Testing and Required Test Results, 2008-09 December 1996</p>	<p>Section 4: Operational and Performance Requirements, Methods of Testing and Required Test Results</p> <p>Section 4A: Measures to Ensure Software Quality</p> <p>Section 4B: ____ System Configurations</p>	
<p>S-32 Appendix 1: Hydrographic Dictionary – Glossary of ECDIS-Related Terms</p>	<p>Section 5: Glossary of Terms</p>	
	<p>Appendix: Product Specification for Inland ENC's incl. IENC Feature Catalogue</p>	

(Maritime) ECDIS	Inland ECDIS	OPEN ECDIS FORUM http://ienc.openecdis.org
	<ul style="list-style-type: none"> IENC Encoding Guide Codes for Producers and Waterways Presentation Library for Inland ECDIS incl. Lookup Tables Symbols Conditional Symbology Procedures 	

SECTION 1: PERFORMANCE STANDARD FOR INLAND ECDIS

1. INTRODUCTION

- (a) Inland ECDIS contributes to safety and efficiency of inland shipping and thereby to the protection of the environment.
- (b) Inland ECDIS reduces the navigational workload as compared to traditional navigation and information methods.
- (c) Inland ECDIS can be designed for both, **information mode** and **navigation mode**, or for **information mode** only.
- (d) For the **navigation mode** as specified in Section 4 of these technical specifications, Inland ECDIS (Operating System Software, Application Software and Hardware) shall have a high level of reliability and availability; at least of the same level as other means of navigation.
- (e) Inland ECDIS shall use chart information as specified by Sections 2 and 3 of these technical specifications.
- (f) Inland ECDIS shall facilitate simple and reliable updating of the Inland ENC.
- (g) Inland ECDIS shall provide appropriate alarms or indications with respect to the information displayed or malfunction of the equipment.
- (h) Inland ECDIS shall meet the requirements of this performance standard.

2. DEFINITIONS

2.1 Terms

These terms and others are also explained in Section 5: Glossary.

For the Inland ECDIS performance standard the following definitions apply:

- (a) **Inland ECDIS** means an electronic chart display and information system for inland navigation, displaying selected information from an Inland System Electronic Navigational Chart (Inland SENC) and, optionally, information from other navigation sensors.
- (b) **Inland Electronic Navigational Chart (Inland ENC)** means the database, standardised as to content, structure and format, issued for use with inland electronic chart display and/ or information systems operated onboard of vessels transiting inland waterways. An IENC is issued by or on the authority of a competent government agency, and conforms to standards initially developed by the International Hydrographic Organization (IHO) and refined by the Inland ENC Harmonization Group. An IENC contains all the chart information necessary for

safe navigation on inland waterways and may contain supplementary information in addition to that contained in the paper chart (e.g. sailing directions, machine-readable operating schedules, etc) which may be considered necessary for safe navigation and voyage planning.~~Inland ECDIS. The Inland ENC complies with the IHO standards S-57 and S-52, enhanced by the additions and clarifications of these technical specifications for Inland ECDIS. The Inland ENC contains all essential chart information and may also contain supplementary information that may be considered as helpful for navigation.~~

- (c) **Inland System Electronic Navigational Chart (Inland SENC)** means a database resulting from the transformation of the Inland ENC by Inland ECDIS for appropriate use, updates to the Inland ENC by appropriate means and other data added by the skipper. It is this database that is actually accessed by the Inland ECDIS for display generation and other navigational functions. The Inland SENC may also contain information from other sources.
- (d) **Minimum Information Density (display base)** means the minimum amount of SENC information that is presented and which cannot be reduced by the operator, consisting of information that is required at all times in all geographic areas and under all circumstances.
- (e) **Standard Information Density (standard display)** means the default amount of SENC information that shall be visible when the chart is first displayed on Inland ECDIS.
- (f) **All Information Density (all display)** means the maximum amount of SENC information. Here, in addition to the standard display, also all other features are displayed, individually on demand.
- (g) **User-defined settings** mean the possibility to use and store a profile of display and operation controls-settings.
- (h) **Integrated Display** means a head-up, relative-motion picture consisting of the SENC overlaid with the radar-image with matching scale, offset and orientation.
- (i) **Navigation mode** means the use of the Inland ECDIS for conning the vessel with overlaid radar image.
- (j) **Information mode** means the use of the Inland ECDIS for information purposes only without overlaid radar image.

2.2 References

- (a) IHO Special Publication No. S-57 "IHO Transfer Standard for Digital Hydrographic Data", Edition 3.1, Supplement No 2, June 2009~~November 2000~~
- (b) IHO Special Publication No. S-62 "ENC Producer Codes", Edition 2.52, December 2009~~March 2006~~
- (c) IHO Special Publication No. S-52 "Specifications for Chart Content and Display Aspects of ECDIS", 65th Edition, March 2010~~December 1996~~, including

~~-S-52 Appendix 1 "Guidance on Updating the Electronic Chart", 3rd-Edition 3.0, December 1996~~
~~July 1997,~~

~~-S-52 Appendix 2 "Colour and Symbols Specifications for ECDIS", Edition 4.2, March 2004 and~~

~~- S-52 Appendix 3 "Glossary of ECDIS-related Terms", 3rd Edition, December 1997~~

(d) IMO Resolution MSC.232(82)A.817(19) "Revised Performance Standards for Electronic Chart Display and Information Systems (ECDIS)", December 2006~~November 1995~~

(e) IEC-Guideline 61174, edition 3.0 "ECDIS - Operational and performance requirements, methods of testing and required test results", 2008-9~~December 1996~~

(f) Annex IX, Part III to VI, of EU-Directive 2006/87: Requirements applicable to radar installations and rate-of-turn indicators and~~ZKR-Beschluss 2008-II-11 (Änderung der Rheinschiffahrtspolizeiverordnung und der Rheinschiffsuntersuchungsordnung im Hinblick auf die Mindestanforderungen und Prüfbedingungen für Navigationsradaranlagen und Wendeanzeiger in der Rheinschiffahrt sowie deren Einbau, zur Anpassung an europäische Richtlinien zur elektromagnetischen Verträglichkeit sowie einschlägige europäische und weltweite Normen und zur Neuordnung der Regelwerke der Zentralkommission, mit den Anlagen 1 und 2, in Kraft getreten am 1.12.2009~~ZKR-Beschlüsse 1989-II-33, 34 und 35 (Vorschriften betreffend die Mindestanforderungen, die Prüfbedingungen, den Einbau und die Funktionsprüfung von Navigationsradaranlagen und Wendeanzeigern in der Rheinschiffahrt, Fassungen vom 1.1.2004)

(g) IHO Special Publication No. S-32 Appendix 1 "Glossary of ECDIS-related Terms".

3. CONTENTS, PROVISION AND UPDATING OF CHART INFORMATION

3.1 Contents and provision of Inland ENCs

(a) The chart information to be used in Inland ECDIS shall be the latest edition of information.

(b) Provisions shall be made to prevent the user from altering the contents of original Inland ENC editions.

(c) If the chart is intended to be used for **navigation mode** (Chapter 5.2 of this Section), at least the following features shall be included in the ENC:

- bank of waterway (at mean water level)
- shoreline construction (e.g. groyne, longitudinal control dam, training wall – any facility that is considered a hazard to navigation)
- contours of locks and dams

- boundaries of the fairway / navigation channel (if defined)
- isolated dangers in the fairway / navigation channel under water
- isolated dangers in the fairway / navigation channel above water level, such as bridges, overhead cables etc.
- Official aids-to-navigation (e.g. buoys, beacons, lights, notice marks)
- waterway axis with kilometres and hectometres or miles
- location of ports and transshipment sites.
- reference data for water level gauges relevant to navigation.
- links to the external xml-files with operation times of restricting structures, in particular locks and bridges.

- (d) If the chart is intended to be used for **navigation mode** (Chapter 5.2 of this Section), the respective competent authority decides for each waterway or harbour within its geographical area of responsibility which of the above named features are to be verified. The respective competent authority shall declare which Inland ENC's are approved for **navigation mode** within its geographical area of responsibility. (For details see Section 2A of these technical specifications).

3.2 Updates

- (a) Inland ECDIS shall be capable of accepting updates to the Inland ENC data provided in conformity with the agreed standards. These updates shall be applied to the SENC automatically. The implementation procedure shall not interfere with the display in use.
- (b) Inland ECDIS shall allow display of updates, so that the skipper may review their contents and ascertain that they have been included in the SENC.
- (c) Inland ECDIS shall be capable of revoking automatically applied updates of the Inland ENC data.
- (d) Original Inland ENC editions and later updates shall never be merged.
- (e) The Inland ENC and all updates to it shall be displayed without any degradation of their information content.
- (f) The Inland ENC data and updates to it shall be clearly distinguishable from other information.
- (g) Inland ECDIS shall ensure that the Inland ENC and all updates to it have been correctly loaded into the SENC.

- (h) Inland ECDIS shall keep a record of updates, including the time of application to the SENC.
- (i) The contents of the SENC to be used shall be adequate and up to date for the intended voyage.

4. PRESENTATION OF INFORMATION

4.1 Display requirements

- (a) The display method shall ensure that the displayed information is clearly visible to more than one observer in the typical conditions of light experienced in the wheelhouse of a vessel by day and night.
- (b) The display size of the chart presentation shall be at least 270 mm by 270 mm for equipment designed and admitted for the **navigation mode**. In **information mode** ergonomic aspects shall determine the size.
- (c) The display requirements shall be met whether in landscape or in portrait format.

4.2 Display ranges (scales)

- (a) In **information mode** (refer to Chapter 5.1 of this Section), it is recommended to use the same ranges as specified in the **navigation mode**.
- (b) In **navigation mode** (refer to Chapter 5.2 of this Section), only the successive switchable ranges (scales) specified in Section 4, Chapter 4.7 of these technical specifications are allowed.

4.3 Image positioning and orientation

- (a) In **information mode** all kinds of chart orientation are allowed (see Chapter 5.1 of this Section)
- (b) In **navigation mode** the chart shall be automatically positioned and oriented in the relative motion, head-up orientation with the own ship's position in the screen centre or off-centred (see Chapter 5.2 of this Section).

4.4 Display of SENC information

- (a) The display of SENC information shall be divided into the following three display categories:
 - Display Base
 - Standard Display
 - All Display

The allocation of the feature classes to the display categories is given in detail in the Look-up Tables of ~~IHO S-52, Appendix 2, Annex A (Presentation Library) and of~~

Appendix 2 “Presentation Library for Inland ECDIS” of these technical specifications.

- (b) The Display Base category shall contain at least the following features:
- bank of waterway (at mean water level)
 - shoreline construction (e.g. groyne, longitudinal control dam, training wall – any facility that is considered a hazard to navigation)
 - contours of locks and dams
 - boundaries of the fairway / navigation channel (if defined)
 - isolated dangers in the fairway / navigation channel under water
 - isolated dangers in the fairway / navigation channel above water level, such as bridges, overhead wires etc.
 - official aids-to-navigation (e.g. buoys, lights and beacons)
- (c) The Standard Display category shall contain at least the following features:
- the objects of Display Base category
 - prohibited and restricted areas
 - piers for commercial vessels (cargo and passenger)
 - kilometre and hectometre or mile marks on the banks
- (d) The All Display category shall display all features that are contained in the Inland SENC, individually on demand.
- (e) When invoking the Inland ECDIS, it shall come up with the Standard Information Density at an appropriate range available in the SENC for the displayed area.
- (f) Inland ECDIS shall be switchable to the Standard Information Density at any time by a single operator action.
- (g) Inland ECDIS shall clearly indicate the information density currently in use at all times.
- (h) Time variable depth information in the ENC shall be displayed independently of the above named three display categories.

4.5 Display of radar information

- (a) In **navigation mode** the radar image shall have the highest display priority and it is only allowed to be presented in the relative motion, head-up mode. If the system is also type approved for maritime ECDIS, true motion and north-up mode may be

implemented. If such a system is used in true motion and/or north-up mode on European inland waterways, it is considered to be working in **information mode**.

- (b) The under laid SENC shall match in position, range and orientation. The radar image and the position from the position sensor shall both be adjustable for the antenna offset to the conning position.
- (c) The overlaid radar image shall conform to the minimum requirements as specified in Section 4, Chapter 4.14 of these technical specifications.
- (d) The overlaid radar image may contain additional navigational information. Any additional navigational information and tracking and tracing symbols shall however in no way degrade the display of the original radar content.

4.6 Display of other navigational information

- (a) Inland ECDIS and additional navigational information shall use a common reference system.
- (b) It shall be possible to display the skipper's own ship's position on the screen.
- (c) It shall be possible for the skipper to select safety limits.
- (d) Inland ECDIS shall indicate the falling short of the safety limits.

4.7 Colours and symbols

- (a) The display of colours and symbols to represent SENC information shall at least be able to comply with the regulations of Section 3 of these technical specifications. Additionally other user-selectable symbol sets are allowed.
- (b) To present navigational elements and parameters as listed in the IMO Resolution [MSC.232\(82\)A.817\(19\)](#), Appendix 3, other colours and symbols than those mentioned in 4.7.a shall be used.

4.8 Data and display accuracy

- (a) The accuracy of the calculated data that are presented shall be independent of the display characteristics and shall be consistent with the SENC accuracy.
- (b) The Inland ECDIS shall provide an indication whether the display uses a smaller display range than the accuracy of the Inland ENC data offers (over-scale indication).
- (c) The accuracy of all calculations performed by Inland ECDIS shall be independent of the characteristics of the output device and shall be consistent with the SENC accuracy.
- (d) Bearings and distances drawn on the display or those measured between features already drawn on the display shall have accuracy no less than that afforded by the resolution of the display.

5. OPERATION

5.1 Information mode

- (a) **Information mode** shall be used for information only and not for navigation.
- (b) In **information mode** all kinds of chart orientation, rotation, zooming and panning are allowed. However, it is recommended to use the same fixed ranges as in the **navigation mode** and the chart orientation whether
 - to north, or
 - to the fairway axis at the actual position, or
 - to the actual ships-heading.
- (c) It should be possible to scroll the chart manually on the screen with the fairway axis in line with the vertical screen axis.
- (d) Inland ECDIS may be connected to a positioning sensor to scroll the chart picture automatically and to display the section of chart matching the actual surrounding, namely in the operator-selected range.
- (e) Information regarding the position and orientation of other vessels, gathered by communication links like AIS, should be only displayed if they are up-to-date (nearly real-time) and accurate. The position and the orientation of other vessels by
 - a directed triangle or
 - a true outline (to scale)

should be not presented if the heading of these other vessels is not available. A generic symbol is recommended.

The following time out values are recommended: (from IEC 62388:)

<u>Category of vessel</u>	<u>Nominal reporting interval</u> class A	<u>Maximum time out value</u> class A	<u>Nominal reporting interval</u> class B	<u>Maximum time out value</u> class B
<u>Vessel at anchor or moored and not moving faster than 3 knots (class B not moving faster than knots)</u>	<u>3 min</u>	<u>18 min</u>	<u>3 min</u>	<u>18 min</u>
<u>Vessel at anchor or moored and moving at more than 3 knots</u>	<u>10 s</u>	<u>60 s</u>	<u>3 min</u>	<u>18 min</u>
<u>Vessel operating in SOLAS mode, moving 0 to 14 knots</u>	<u>10 s</u>	<u>60 s</u>	<u>30 s</u>	<u>180 s</u>
<u>Vessel operating in SOLAS mode, moving 0 to 14 knots and changing course</u>	<u>3 1/3 s</u>	<u>60 s</u>	<u>30 s</u>	<u>180 s</u>
<u>Vessel operating in SOLAS mode, moving 14 to 23 knots</u>	<u>6 s</u>	<u>36 s</u>	<u>30 s</u>	<u>180 s</u>
<u>Vessel operating in SOLAS mode, moving 14 to 23 knots and changing course</u>	<u>2 s</u>	<u>36 s</u>	<u>30 s</u>	<u>180 s</u>
<u>Vessel operating in SOLAS mode, moving faster than 23 knots</u>	<u>2 s</u>	<u>30 s</u>	<u>30 s</u>	<u>180 s</u>
<u>Vessel operating in SOLAS mode, moving faster than 23 knots and changing course</u>	<u>2 s</u>	<u>30 s</u>	<u>30 s</u>	<u>180 s</u>
<u>Vessel operating in inland waterway mode</u>	<u>2 – 10 s</u>	<u>60 s</u>	=	=

The AIS targets should be marked as outdated if the position information of moving vessels is older than 30 seconds.

Information on the intention (blue sign) or the number of blue cones of other vessels, the status of signals, weather warnings (EMMA) and the water level received via Inland AIS may be displayed. The information on the intention (blue sign) should only be displayed on the right side of the symbol, if the heading of the vessel is available. If no heading information is available the information should only be displayed in a direction independent form. The following table is providing an example for the display:

Visualization of Blue Sign status 0 to 2 and dangerous goods							
Blue Sign		Not connected or not available		Not set		Set	
Blue cones		no	1 to 3	no	1 to 3	no	1 to 3
Heading	No						
	Symbol						
	True shape						

5.2 Navigation mode

- (a) In **navigation mode**, the Inland ECDIS display shall be integrated with the own ship's radar information. The radar information shall be clearly distinguishable from the SENC information.
- (b) The integrated display shall be in accordance with the requirements for radar on inland waterways as specified in Section 4, Chapter 4.14 of these technical specifications.
- (c) The chart and the radar image shall match in size, position and orientation within the limits as specified in Section 4, Chapter 3.4 and 8.3.2 of these technical specifications.
- (d) The Integrated Display shall only be presented in the head-up orientation. Other orientations are permitted in systems with an additional maritime ECDIS type approval. If such a system is used in true motion and/or north-up mode on European inland waterways, it is considered to be working in **information mode**.
- (e) It shall be possible for the operator to adjust the off-set values between the positions of the position sensor and the radar antenna displayed position of the vessel so that the SENC display radar image matches the radar image SENC display.
- (f) It shall be possible to remove either the ECDIS or the radar information by a single operator action temporarily.
- (g) The vessel's position shall be derived from a continuous positioning system of which the accuracy is consistent with the requirements of safe navigation.
- (h) **Navigation mode** shall provide an indication when the input from the position-fixing system is lost. **Navigation mode** shall also repeat, but only as an indication, any alarm or indication passed to it from a position fixing system.
- (i) The positioning system and the SENC shall be based on the same geodetic datum.

- (j) In **navigation mode**, the data according to Chapter 3.1.c of this Section shall always be visible and shall not be obscured by other objects.
- (k) Information regarding the position and orientation of other vessels, gathered by other communication links than the own radar, are permitted to be displayed only if they are up-to-date (nearly real-time) and meet the accuracy that is required for the support of tactical and operational navigation. Position information of the own vessel that is received from a repeater station shall not be displayed.
- (l) As tracking and tracing information (for example AIS) of other vessels is useful for the planning of the passing, but of no use during passing itself, tracking and tracing (AIS) symbols shall not disturb the radar image during passing and shall be faded out therefore. Preferably the application shall allow the skipper to define the area where the symbol is faded out.
- (m) The presentation of the position and the orientation of other vessels by
 - a directed triangle or
 - a true outline (to scale)

are permitted only if the heading of these other vessels is available. In all other cases a generic symbol shall be used (an ~~octagon~~ square is recommended, a circle must not be used for applications which are certified according to maritime standards ~~a circle shall be used for inland applications only~~).

- n) Information that another vessel is carrying blue cones or lights may be displayed by a different colour of the vessel symbol. The number of the blue cones/lights should only be displayed in the pick report. ~~The user should be able to switch off the display of the information on blue cones.~~
- o) Information on the intention of another vessel to pass on starboard (blue sign) may only be displayed on the right side of the directed triangle symbol or of the scaled shape if the heading of this vessel is available. If no heading information is available the information shall only be displayed in a direction independent form.
- p) Information regarding the position of AIS base stations, AIS Aids to Navigation (ATON) and AIS Search and Rescue Transmitters (SART) may be displayed, if the symbols can be distinguished from other symbols (e.g. symbols 2.10 and 2.11 of IEC 62288 Ed. 1, Table A.1).

5.3 Operation and control elements

- (a) Inland ECDIS shall be designed following ergonomic principles for user-friendly operation.
- (b) The Inland ECDIS equipment shall have a minimum of operation and control elements (see Section 4 of these technical specifications).
- (c) Operation and control elements, and indicators for connected sensors, may be integrated in Inland ECDIS.

- (d) Standard settings and user-defined settings shall be easily retrievable.

6. CONNECTIONS WITH OTHER EQUIPMENT

- (a) Inland ECDIS shall not affect the performance of any connected equipment adversely. Similarly the connection of optional equipment shall not degrade the performance of Inland ECDIS.
- (b) Inland ECDIS shall be capable of generating information to other systems, e.g. for the purpose of electronic reporting.
- (c) The relevant requirements of controls and indicators to connected equipment shall be fulfilled.

7. INDICATIONS AND ALARMS

7.1 Built in Test Equipment (BITE)

Inland ECDIS shall be provided with means for carrying out on board tests of major functions either automatically or manually. In case of a failure, the module at fault shall be shown.

7.2 Malfunctions

Inland ECDIS shall provide a suitable alarm or indication of system malfunctions (refer to Section 4, Chapter 9 of these technical specifications).

8. FALLBACK ARRANGEMENTS

8.1 Insufficient accuracy of the SENC-positioning

In **navigation mode** the SENC shall be automatically switched off, if the SENC positioning does not match the radar picture within the limits of Section 4, Chapter 5.1 and 5.2 of these technical specifications.

8.2 Defects

- (a) If the Inland ECDIS system has an evident defect, it shall provide a suitable alarm (refer to Section 4, Chapter 4.16 and 9 of these technical specifications).
- (a) Facilities enabling a safe take-over of the Inland ECDIS functions shall be provided in order to ensure that an Inland ECDIS failure does not result in a critical situation.

9. POWER SUPPLY IN NAVIGATION MODE

- (a) The Inland ECDIS shall have its own separate fused power supply.

(b) — ~~Interruptions of the power supply for a period up to 5 minutes shall not have any influence on correct operation and shall not require restarting of the equipment manually.~~

SECTION 2: DATA STANDARD FOR INLAND ENCS

1. INTRODUCTION

- (a) This Data Standard for Inland ENCs describes the technical specifications to be used
 - for the exchange of digital hydrographic data between national inland waterway authorities and
 - for its distribution to manufacturers, skippers and other users.
- (b) This Data Standard shall be used for the production of Inland ENCs. The transfer and distribution shall take place in such a way that none of the information is lost.
- (c) This Data Standard is based on the “IHO Transfer Standard for Digital Hydrographic Data”, Special Publication No. 57, Edition 3.1 [Supplement No 2](#) with all Appendices and Annexes (see comparison table in the beginning of these Inland ECDIS technical specifications), in brief "S-57".
- (d) This Data Standard describes the necessary additions and clarifications to S-57 and the application of S-57 for the purpose of use in Inland ECDIS applications.
- (e) This Data Standard comprises
 - this Section 2
 - Appendix 1 Product Specification for Inland ENCs, Appendix 1.1 Inland ENC Feature Catalogue and Appendix 1.2 Inland ENC Encoding Guide.

2. THEORETICAL DATA MODEL

The description of the theoretical data model in S-57 Part 2 shall apply to the theoretical data model of Inland ENCs.

3. DATA STRUCTURE

The description of the data structure in S-57 Part 3 shall apply to the data structure of Inland ENCs.

4. PRODUCT SPECIFICATION FOR INLAND ENCS

The Product Specification for Inland ENCs (Appendix 1) is a set of specifications intended to enable chart producers to produce a consistent Inland ENC, and manufacturers to use that data efficiently in an Inland ECDIS that satisfies the Performance Standard for Inland ECDIS (Section 1 of these technical specifications).

An Inland ENC shall be produced in accordance with the rules defined in these specifications and shall be encoded using:

- the Inland ENC Feature Catalogue(Appendix 1.1) and
- the rules described in the Inland ENC Encoding Guide (Appendix 1.2).

Official Inland ENCs shall be produced in accordance with the latest version of the 'Data Standard' including the 'Product Specification'. Official Inland ENCs, which have been produced in accordance with Edition 1.02 of the Inland ECDIS Standard and before the entry into force of these technical specifications remain valid until new editions of Official Inland ENCs are published in accordance with these technical specifications.

5. DEFINITIONS

Definitions of terms may be found in

- S-57, part 1, clause 5
- the "Glossary of ECDIS Related Terms" in [S-32](#) Appendix ~~13 to S-52~~
- the "Glossary of Terms" in Section 5 of these technical specifications.

6. PROCEDURES FOR CHANGES OF THE APPENDICES

Proposals for amendments of Appendix 1 Product Specification for Inland ENCs and its Appendices 1.1 and 1.2, Inland ENC Feature Catalogue and Inland ENC Encoding Guide shall be submitted at <http://ienc.openecdis.org>. They shall contain an explanation why the amendment is needed.

Proposals for amendments of Appendix 1.1 Inland ENC Feature Catalogue shall include a proposal for an amendment of Appendix 1.2 Inland ENC Encoding Guide with regard to the use of these amendments. Each new version of the Feature Catalogue for Inland ENC results in a new version of the Product Specification for Inland ENCs.

The chairperson of the Inland ECDIS Expert Group shall inform the European Commission accordingly.

As regards the Inland ECDIS Expert Group and the Inland ENC Harmonisation Group, the amendment procedure as defined in their respective Terms of Reference shall apply.

The European Commission will proceed with the amendment in accordance with the relevant procedure established in Directive 2005/44/EC. In this context, one shall take due account of the conclusions of the Inland ECDIS Expert Group and the Inland ENC Harmonisation Group.

If a proposal for amendment is adopted, the relevant updated documents are uploaded at http://ec.europa.eu/transport/iw/index_en.htm and at <http://ienc.openecdis.org>.

SECTION 2A: CODES FOR PRODUCERS AND WATERWAYS (IN ADDITION TO IHO-S-62 ENC PRODUCER CODES)

Codes for producers of Inland ENCs as well as the registration procedure are made available at http://ec.europa.eu/transport/iw/index_en.htm and <http://iencwww.openeedis.org>, if they are not already mentioned in IHO S-62.

If administrations or private companies decide to produce Inland ENCs, they shall register a producer code at the S-100 registry of IHO “Open ECDIS Forum” at <http://registry.iho.intwww.openeedis.org>.

The notification of competent authorities in accordance with Article 8 of Directive 2005/44/EC shall include information on the geographical area of responsibility and the official website of the competent authorities. Member States shall notify the Commission immediately of any changes.

The competent authorities referred to in Article 8 of Directive 2005/44/EC shall maintain and provide via its official website an up-to-date list of Official Inland ENCs approved for the **navigation mode** within its geographical area of responsibility. The list shall include the file name of the cell, the stretch of the inland waterway that is covered, the edition number, the issue date and a list of available update files to the currently valid edition also with their issue dates. By putting an Inland ENC on that list the competent authority declares this cell as verified with respect to the minimum content and therefore approved for **navigation mode**.

The list of competent authorities (including their geographical area of competence and their web address) will be maintained and uploaded by the European Commission at http://ec.europa.eu/transport/iw/index_en.htm.

The following Codes for Waterways are recommended for use in the file name of IENCs:

Waterway Name	Waterway Code	Remark
Danube	D	(with Sulina branch)
Danube	DA	Chilia branch
Danube	DCC	Cernavoda canal
Neckar	NE	
Main	MA	
Mosel	MO	
Elbe	EL	
Rhine	RH	
Nederrijn / Lek	RL	
Waal	WA	
Drava	DR	
Tisza	TI	
Sava	SA	
Dunarea Veche	DV	
Dunarea Barcea	DB	
Sf. Gheorghe Arm	GA	
Olt	OL	
Sio-chatorna	SI	
Balaton	BA	
Danube	DUM	Mosoni Duna
Danube	DUS	Szenterei Duna
Danube	DUK	Rackevei Duna

Waterway Code	Waterway Name	Remark
BA	Balaton	
BK	Boudewijn Kanaal	

BSK	Berlin-Spandauer Schiffahrtskanal	including Westhafenkanal and Charlottenburger Verbindungskanal
BZ	Beneden Zeeschelde	
D	Danube	including Sulina branch
DA	Danube Chilia branch	
DB	Dunarea Barcea	
DCC	Danube Cernovoda canal	
DE	Dortmund-Ems Kanal	
DD	Desna	
DN	Dnipro	
DNP	Prypiat	
DNS	Sula	
DNV	Vorskla	
DR	Drava	
DUK	Rackevei-Duna	
DUM	Mosoni-Duna	
DUS	Szenterei-Duna	
DV	Dunarea Veche	
EL	Elbe	
EH	Elbe-Havel-Kanal	
EMS	Ems	
ES	Elbe-Seiten-Kanal	
EV	Estuaire Vaart	Estuary shipping between Zeebrugge and Dutch border
GA	St. Gheorghe-Arm	
HO	Havel-Oder-Wasserstraße	including Westoder
KGt	Kanaal Gent-Terneuzen	
MA	Main	
MD	Main-Donau-Kanal	
ME	MÄ¼ritz-Elde-	

	Wasserstraße	
ML	Mittelland-Kanal	
MO	Mosel	
NE	Neckar	
NOK	Nord-Ostsee-Kanal	
OD	Oder	
OL	Olt	
PK	Plassendale Kanaal	
RH	Rhine	
RHK	Rhein-Herne-Kanal	
RL	Nederrijn/Lek	
RU	Ruhr	
SA	Sava	
SE	Schelde	
SI	Sio-chatorna	
SL	Saale	
SO	Spree-Oder- Wasserstraße	
SR	Saar	Currently SA is used; this will be changed to SR with the next edition
TI	Tisza	
UH	Untere Havel- Wasserstraße	
UWE	Unterweser	from km Uwe 0,00
WA	Waal	
WE	Mittelweser	until km 366,65/UWe 0,00

Additional waterway codes can be registered via the “Open ECDIS Forum” at <http://ienc.openecdis.orgwww.openecdis.org>.

SECTION 3: PRESENTATION STANDARD FOR INLAND ECDIS

1. INTRODUCTION

- (a) This Presentation Standard for Inland ECDIS describes the technical specifications to be used for the presentation of Inland ECDIS data. The presentation shall take place in such a way that none of the information is lost.
- (b) This Presentation Standard is based on the document "S-52, Specification for Chart Content and Display Aspects of ECDIS" of the IHO, Edition ~~65-0, March 2010~~ of ~~December 1996~~, with all Appendices and Annexes (see "Comparison of the structures of the standards for (Maritime) ECDIS and Inland ECDIS" in the beginning of these technical specifications).
- (c) This Presentation Standard describes the necessary additions and clarifications to S-52 and the application of S-52 for the purpose of use in Inland ECDIS applications.
- (d) This Presentation Standard comprises
 - this Section 3,
 - the Appendix 2 Presentation Library for Inland ECDIS with additions and clarifications to be applied to S-52, ~~Appendix 2~~, Annex A.
- (e) Definitions of terms may be found in
 - IHO-S-57, Part 1, clause 5,
 - the "Glossary of ECDIS-Related Terms" in ~~S-32~~ Appendix ~~13 to S-52~~,
 - the "Glossary for Inland ECDIS" in Section 5 of these Inland ECDIS technical specifications.

2. THE PRESENTATION LIBRARY FOR INLAND ECDIS

S-57 data sets do not contain any information about how the data is going to be presented. The chart presentation is generated online in the Inland ECDIS application. For that purpose, the Inland ECDIS application uses machine-readable symbolization instructions for each feature, which is drawn on the screen. For the presentation of ENC's the IHO S-52 standard is mandatory. The S-52 standard contains all rules which are necessary for the symbolization and presentation of ENC's on the screen.

Since the features, attributes and attribute values for ENC's were extended for Inland ENC's an extension of the S-52 standard is necessary in order to be able to display also the Inland specific features. All extensions apply to the Edition ~~3.43~~ of the IHO ECDIS Presentation Library (Annex A of ~~Appendix 2 of S-52~~).

2.1 Components of S-52 and Inland ECDIS Presentation Library

The major components of the S-52 presentation library are:

- A library of symbols, line styles and fill styles
- A colour coding scheme which includes the IHO colour tables for day, dusk and night time
- A set of symbology command words from which machine readable instructions can be assembled. The result is a symbology instruction, which is processed to symbolise ENC features in turn.
- A set of conditional symbology procedures to decide the appropriate symbolisation in cases determined by the mariner's selection (e.g. safety contour) or for complex symbols (e. g. top marks on buoys and beacons)
- A set of look-up tables that link feature descriptions from the ENC to the appropriate symbology instructions depending on whether:
 - the link is straight forward, i.e. a direct relationship between a feature's description and its presentation such as a buoy or a land area. In this case, the look-up table provides the symbology instruction to show a symbol, an area fill, or a line style.
 - the link is conditional, i.e. depending on circumstances, for example a depth area, whose colour fill depends on the choice of the safety contour. In this case the look-up table refers the decision to a conditional symbology procedure that selects the appropriate symbology instructions later.

Inland ECDIS shall use all S-52 components plus extensions in:

- Lookup tables
- Symbol library
- Conditional symbology procedures

Only the extensions are described in Appendix 2 Presentation Library for Inland ECDIS.

2.2 Look-up tables

For each geometry type (point, line, area) there is a separate look-up table. Each entry in a look-up table consists of the following fields:

- (a) 6-character code of the feature class (acronym)
- (b) Attribute combination

- (c) Symbolization instructions
- (d) Display priority, 0-9 (comparable with drawing layers)
- (e) Radar code
- (f) Display category (Display base, standard, all other)
- (g) "Viewing group", more refined grouping of features than the display categories

"LNDMRK","CATLMK17 ","SY(TOWERS01)","7","O","OTHER","32250"

Figure 1 - Example entry of a look-up table

In this case the feature LNDMRK is shown by the symbol TOWERS01 with priority 7, if the attribute CATLMK equals 17. The feature lies over the radar.

The presentation of features in a specific area that are contained in different cells of the same usage follows the entries in the look-up tables.

The Presentation Library provides five look-up tables:

- paper chart point symbols
- simplified point symbols
- line symbols
- plain area boundary symbols
- symbolized area boundary symbols

2.3 Conditional symbology procedures (CS)

CS are generated for features of which the symbolization

- depends on application settings, e.g. safety contour,
- depends on other features, e.g. top marks and their structure,
- is too complex to be defined in a direct look-up table entry.

CS Procedures, which shall be modified or implemented in an Inland ECDIS additional to the CS Procedures of S-52 are described in Appendix 2 Presentation Library for Inland ECDIS.

2.4 Colours

Colours used in an ECDIS are defined in an absolute, monitor independent way (CIE coordinates). This ensures that ECDIS charts look similar on monitors of different suppliers.

By means of a colour calibration software which must be used by the manufacturer, CIE values are converted into RGB values.

Commercial displays usual in the trade are seen as matching these requirements.

Because of the different lighting conditions on the bridge of a ship, it is necessary to offer presentations with different brightness. For each level a separate colour table exists.

The represented colour scheme shall be chosen on the basis of ergonomically and physiological factors and the representation of indications in different colours shall not result in mixed colours by superimposing.

2.5 Presentation of notice marks

Notice marks which are located at the river bank are presented in the chart displayed by generic symbols (notmrk01, notmrk02 and notmrk03). This does not apply to the notice marks on bridges.

Additionally applications are required to be able to display the detailed symbol, which is similar to the real world indication, and the full set of object information of a user-selected notice mark.

Notice marks that are located at bridges, shall be symbolized according to the orientation of the bridge.

Notice marks which specify distances or a velocity shall not be symbolized with the number itself, but only with that symbol which gives the general regulation or information.

3. PROCEDURES FOR CHANGES OF THE APPENDICES

Proposals for amendments to Appendix 2 Presentation Library for Inland ECDIS shall be submitted at <http://ienc.openecdis.org>.

They shall contain an explanation why the amendment is needed.

The procedure as described in Section 2 Chapter 6 applies in principle to changes to Appendix 2 Presentation Library for Inland ECDIS too, with the difference that in this case the Inland ENC Harmonisation Group is not concerned.

The chairperson of the Inland ECDIS Expert Group shall inform the European Commission accordingly.

As regards the Inland ECDIS Expert Group, the amendment procedure as defined in its Terms of Reference shall apply.

The European Commission will proceed with the amendment in accordance with the relevant procedures established in Directive 2005/44/EC. In this context, one shall take due account of the work of the Inland ECDIS Expert Group.

If a proposal for amendment is adopted, the relevant updated documents are uploaded at http://ec.europa.eu/transport/iw/index_en.htm and at <http://ienc.openecdis.org>.

SECTION 4: OPERATIONAL AND PERFORMANCE REQUIREMENTS, METHODS OF TESTING AND REQUIRED TEST RESULTS

1. INTRODUCTION

1.1 Subject matter of this Section

This Section specifies the minimum requirements contained in Section 1 of these technical specifications and describes the test procedures and the required results concerning the hardware, the software, the functions, the operation, the display and the interfaces to other equipment on board of ships.

1.2 Normative references

References to the following normative documents are made in this document in addition to the references in Section 1, Chapter 2.2 of these technical specifications:

EN 60945 (1997 <u>2002</u>):	Marine navigational equipment; General requirements - Methods of testing and required test results
IEC <u>61174 Edition 3.0</u> :	ECDIS - Operational and performance requirements, methods of testing and required test results
ISO 9000 (2005 <u>1987</u>):	Quality management and quality assurance standard
<u>EU-Directive 2006/87/EC</u>	<u>Annex IX, Part III to VI: Requirements applicable to radar installations and rate-of-turn indicators</u>
CCNR Decision 2008 <u>1989-II-1133</u> :	<u>Änderung der Rheinschiffahrtspolizeiverordnung und der Rheinschiffsuntersuchungsordnung im Hinblick auf die Mindestanforderungen und Prüfbedingungen für Navigationsradaranlagen und Wendeanzeiger in der Rheinschiffahrt sowie deren Einbau, zur Anpassung an europäische Richtlinien zur elektromagnetischen Verträglichkeit sowie einschlägige europäische und weltweite Normen und zur Neuordnung der Regelwerke der Zentralkommission, mit den Anlagen 1 und 2, in Kraft getreten am 1.12.2009</u> Standard on the minimum requirements and on the required test results for navigational radar equipment in the Rhine navigation
CCNR Decision 1989-II-34 :	Standard on the minimum requirements and on the required test results for rate of turn indicators in the Rhine navigation
CCNR Decision 1989-II-35 :	Standard on the installation and on functional tests of navigational radar equipment and of rate of turn indicators in the Rhine navigation

EU-Directive 1999/5/EC: Radio Equipment and Telecommunications Terminal Equipment and the Mutual Recognition of their Conformity

2. OPERATING MODES AND SYSTEM CONFIGURATION

2.1 Operating modes

- (a) The Inland ECDIS technical specifications distinguish two operating modes: **navigation mode** and **information mode**.
- (b) Inland ECDIS equipment designed for operating in **navigation mode** shall fulfil the requirements of these technical specifications and the standards on navigational radar equipment and rate-of-turn indicators to be proven by conformity tests.
- (c) For Inland ECDIS equipment designed for **information mode** only, the requirements of this Section 4 are to be understood as a recommendation.

2.2 System configurations

2.2.1 *Inland ECDIS equipment, stand-alone-system without connection to radar*

In this configuration only operation in **information mode** is possible (see Section 4B, Fig. 1).

2.2.2 *Inland ECDIS equipment, parallel installation and connection to radar*

This configuration allows operation in **information mode** as well as in **navigation mode** (see Section 4B, Fig. 2).

2.2.3 *Inland ECDIS equipment, monitor shared with connected radar equipment*

In ~~this special~~ cases, ~~the monitor of the radar equipment it is possible to share one display will be shared with for~~ the Inland ECDIS equipment ~~and for the radar equipment~~. ~~The~~ Prerequisite for this ~~mode are is a monitor with~~ matching graphic parameters for both video signals; and a video switch, which allows a fast switchover of the video sources, ~~and if needed a mechanical rotation of the display to the required orientation~~ (see Section 4B B, Fig. 3).

This configuration allows operation in **information mode** as well as in **navigation mode**.

2.2.4 *Radar equipment with integrated Inland ECDIS functionality*

This is a radar installation with integrated Inland ECDIS functionality that can be operated in **information mode** as well as in **navigation mode** (see Sector 4B, Fig. 4).

3. PERFORMANCE REQUIREMENTS

3.1 Hardware performance

- (a) Inland ECDIS equipment shall be designed and manufactured to withstand typical environmental conditions prevailing on board of a vessel without any degradation in quality and reliability. Furthermore, it shall not disturb other communication and navigation equipment.
- (b) In the configuration as described in Chapter 2.2.4 of this Section all components of Inland ECDIS equipment installed inside the wheelhouse, shall fulfil the requirements of the class b) "protected from weather" equipment as specified in the standard EN 60945 with the exception that the test temperature range is limited to 0° C to +40° C (whereas the test temperature range in EN 60945 is specified from – 15° C to + 55° C) unless specified differently in these technical specifications. For the configurations described in Chapter 2.2.2 and 2.2.3 of this Section CE conformity is sufficient.

3.2 Software performance

Software for the operation, visualisation, and functionality of Inland ECDIS equipment shall be designed, developed, implemented, and tested in accordance with the software requirements described in Section 4A to these technical specifications.

3.3 Performance of operation controls

- (a) The operation of the system shall be simple, appropriate and conform to common human interface standards.
- (b) The number of operational controls shall be as low as possible and restricted to the required number.
- (c) Wireless remote controls are not permitted.
- (d) The ON/OFF switch shall perform and shall be arranged in such a way that inadvertent operation is not possible.
- (e) The symbols of the operating controls shall have a minimum character height of 4 mm and shall be readable under all conditions that may exist in a wheelhouse.
- (f) The brilliance and the illumination of the operating controls shall be adjustable to the required value.

3.4 Display performance

3.4.1 Display dimensions

In **navigation mode** the minimum chart and radar display area shall be at least 270 mm x 270 mm.

3.4.2 *Display orientation*

- (a) A rectangular display may be mounted in landscape or in portrait orientation under the prerequisite that the above-mentioned minimum dimensions are fulfilled.
- (b) Because of the limited space available in the typical wheelhouse of an inland vessel and the fact that a vessel usually follows the fairway-axis, the display shall be installed preferably in the portrait orientation.

3.4.3 *Display resolution*

A display resolution of 5 m in the 1,200 m range is required. This leads to a maximum pixel dimension of 2.5 m x 2.5 m, i.e. about 1,000 pixels at the short edge of the display.

3.4.4 *Display colours*

The system shall be able to display ergonomically proven colour combinations for day and night.

3.4.5 *Display brilliance*

The brilliance of the display shall be adjustable to every operational required value. This is especially valid for the lowest value during operation at night.

3.4.6 *Picture renewal*

- (a) The picture renewal rate shall not be shorter than that of the radar picture (≥ 24 pictures per minute).
- (b) Between two consecutive renewals no fluctuations of brilliance shall occur.
- (c) On raster scan displays, the frame repetition rate shall not be lower than 60 Hz.

3.4.7 *Display technology*

Preferably such display systems shall be used that are insensitive to the magnetic fields that may occur in the wheelhouse of an inland vessel.

4. OPERATIONAL FUNCTIONS

4.1 Operating mode

- (a) If the equipment is able to work in both operation modes it shall provide the possibility to switch between **navigation mode** and **information mode**.
- (b) The operation mode in use shall be displayed.
- (c) Suitable measures are required to prevent inadvertent switching off of the **navigation mode**.

4.2 Equipment pre-sets (store/recall)

- (a) After invoking, the Inland ECDIS equipment shall come up with a moderate brilliance pre-set which neither blinds in a dark environment nor makes the picture invisible in a bright environment.
- (b) Other parameters may come up with their values at the time before switching off or from stored settings.

4.3 Presentation of SENC information

- (a) The radar picture shall be clearly distinguishable from the chart independently of the chosen colour table.
- (b) Only a monochrome presentation of the actual radar picture is permitted.
- (c) The presentation of chart information shall not mask or degrade important parts of the radar picture. This shall be ensured by appropriate entries into the look-up tables (refer to Section 3 of these technical specifications, Chapter 2.2, field "radar code").
- (d) In **navigation mode**, chart and radar picture presentation shall have the same scale.
- (e) The heading line shall be always visible.
- (f) Additionally, the mariner's own ship's contour and the safety contours may be inserted.

4.4 Chart orientation, positioning and shifting

- (a) In **navigation mode**, only the chart orientation "relative motion, head up" and the "centred" or "off centred" presentations, as required for the radar picture, are permitted.
- (b) In **information mode**, at least the chart orientations 'north' and 'parallel to the waterway axis' as well as positioning are recommended. By connection of a positioning sensor, the displayed part of the chart can automatically follow the mariner's own ship's position.

4.5 Position and bearing of the own ship

- (a) In **navigation mode**, the own ships position shall always be visible in the display area, whether "centred" or "off centred", as specified in the CCNR radar requirements.
- (b) The heading line, which runs from the display centre to the top and which shall be always visible, shall represent the heading of the mariner's own ship.

4.6 Information density

The information density shall be at least adjustable to the three switch steps: "Minimum", "Standard" and "All Information". The latter displays all other features in addition to the "Standard" display, individually on demand. All corresponding visible features are defined in

the "Performance Standard" and the "Presentation Standard" (incl. the "Presentation Library for Inland ECDIS") (Sections 1 and 3 of these technical specifications).

4.7 Ranges/Range rings

- (a) In **navigation mode** the following fixed ranges and range rings are prescribed according to the radar regulations:

Range	Range rings
500 m	100 m
800 m	200 m
1,200 m	200 m
1,600 m	400 m
2,000 m	400 m
<u>4,000 m</u>	<u>800 m</u>

- (b) Smaller and larger ranges with a minimum of four and a maximum of six range rings are permitted.
- (c) Inland ECDIS equipment in **navigation mode** shall have fixed range rings with the above-mentioned intervals and at least one variable range marker (VRM).
- (d) Switching on/off of fixed and variable range markers shall be independent of each other and their display shall be clearly distinguishable.
- (e) The position of the VRM and the corresponding displayed distance shall use the same increments and resolution.
- (f) The functions of the VRM and the electronic bearing line (EBL) may additionally be realised by a cursor and by a corresponding numerical display, showing range and bearing of the cursor position.
- (g) For **information mode** the same ranges are recommended.

4.8 Picture brilliance

- (a) The brightness of the display shall be adjustable to the operationally necessary value. This applies in particular to operation in darkness.
- (b) Chart and radar picture shall have separate brightness controls.
- (c) Because of the strongly different environment brightness of bright day and dark night, another control for the basic brightness of the display shall be available additionally to the colour tables in the menu.

4.9 Picture colours

At least the colour combinations included in the IHO-S-52 Presentation Library, Chapter 4 and 13 (*colour tables*) for bright day, white-back day, black-back day, dusk and night shall be supported.

4.10 Pick report

- (a) In **navigation mode**, it shall be possible to get all underlying textual and/or graphical information concerning user selections of the features that are displayed in the chart.
- (b) This additional textual and/or graphical information shall not hamper the view of the waterway in the navigational chart.

4.11 Measuring features

- (a) Measuring features for distances and bearings are required.
- (b) Resolution and accuracy shall at least be the same as those of the display, but may not suggest better values than those of the chart data.

4.12 Input and editing of skippers' own chart entries

- (a) Inland ECDIS equipment shall allow input, storing, modifying and deletion of additional chart information by the skipper (skippers' own features).
- (b) These own chart entries shall be distinguishable from the SENC data, and shall not overlay or degrade the radar picture.

4.13 Loading and updating of SENC's

- (a) All **manual** activities concerning loading or updating of charts shall be possible only outside the **navigation mode**.
- (b) **Automatic** updating shall not downgrade the performance of the navigation display.
- (c) A **rollback function** shall be implemented to allow restoring to the last working combination.

4.14 Radar picture presentation and overlay

- (a) The radar image representation is mandatory for operation in the **navigation mode**.
- (b) The dimensions, resolution and attributes of the radar presentation shall fulfil the relevant radar requirements.
- (c) The radar picture shall not be degraded by other contents of the picture (see also Chapter 4.3.c of this Section).
- (d) Provided the functional requirements are fulfilled, overlaying of different information layers is permitted.

(e) The overlay of information regarding the position and orientation of other vessels is only allowed when:

- the information is up-to-date (nearly real-time) and
- ~~the age of the information does not exceed 5 seconds~~
- the age of information does not exceed the maximum time out values provided in the table in 5.1 (e) of section 1, Performance Standard for Inland ECDIS. The symbols shall be marked as outdated, if the age of the information exceeds 30 seconds for moving vessels. The position information of the own vessel shall not be displayed, if it is received from a repeater station.

(f) The overlaid information derived from tracking and tracing devices regarding the position and orientation of other vessels shall be faded out at a user-definable range.

(g) The presentation of the position and the orientation of other vessels by

- a directed triangle or
- a true outline (to scale)

are permitted only if the heading of these other vessels is available. In all other cases a generic symbol shall be used (an octagon square is recommended, a circle shall be used for inland applications only).

(h) It shall be possible to switch off the chart and any other information layer and to display only the radar picture by one easily accessible control element or menu area.

(i) If the quality and plausibility monitoring of the Inland ECDIS equipment detect that the chart cannot be oriented and/or positioned with the accuracy required by these technical specifications, an alarm shall be presented on the display and the chart shall be switched off automatically.

4.15 Inland ECDIS functions with immediate access

(a) The following operational functions require direct access:

- RANGE
- BRILLIANCE
- COLOURS
- INFORMATION DENSITY

(b) These functions shall have either own control elements or own menu areas, which are arranged in the highest menu level and are permanently visible.

4.16 Permanently visible function parameters

The following function parameters shall always be visible:

- actual RANGE
- sensor STATUS (radar tuning, position quality, alarms)
- selected WATER LEVEL (if available)
- selected SAFETY DEPTH (if available)
- selected INFORMATION DENSITY

5. SERVICE FUNCTIONS

Service functions shall be protected by password or other suitable measures against unauthorised access and shall not be selectable in **navigation mode**.

5.1 Static correction of the chart position

- (a) The position of the mariner's own ship shall be presented “centred” or “off centred” on the display in accordance with the radar requirements. The chart position shall match the radar image. Assuming an absolute position's input the permissible static difference between actual radar position and displayed radar centre shall not exceed 1 m.
- (b) It shall be possible to correct an offset error (distance between the positions of the position sensor and the radar sensor).

5.2 Static correction of the chart orientation

- (a) The difference between the heading line orientation and the ship's axis shall not be greater than ± 1.0 degree.
- (b) Chart and radar image shall have the same orientation. The static directional error between heading line and chart orientation shall be less than ± 0.5 degree.

5.3 Configuration of interfaces

- (a) It shall be possible to configure interfaces for connected sensors, actors and signals [An actor transforms an electrical quantity into another physical quantity (e.g. optical). An actor is the opposite of a sensor].
- (b) Interfaces shall comply with existing interface specifications like the NMEA 01/83 standard and the interface specifications for rate of turn indicators (20 mV/deg/min).

6. HARDWARE TEST AND REQUIRED CERTIFICATES

- (a) The test shall consist of a comparison between the equipment under test (EUT) and the requirements of these technical specifications.
- (b) Proved equivalent tests, and proved and documented test results shall be accepted without renewed tests.

6.1 Compatibility with the environmental requirements

- (a) Inland ECDIS equipment, as described in Chapter 2.2.4 of this Section, shall fulfil the requirements of the Standard EN 60945 concerning the environmental conditions (humidity, vibration and temperature; the latter reduced according to Chapter 3.1 of this Section) and concerning electromagnetic compatibility.
- (b) The provider or his representative shall submit a relevant conformity declaration of an accredited laboratory.

6.2 Equipment documentation

The technical documentation shall be checked to be complete, appropriate, and understandable, and to be sufficient for unproblematic installation, configuration and operation of the equipment.

6.3 Interfaces

- (a) All interfaces shall be documented correctly and completely.
- (b) Electronic circuits shall be designed failsafe, mechanically as well as electronically, and shall not have degrading repercussions on connected equipment.

6.4 Characteristic of operation controls

All operation controls shall be checked regarding the ergonomic and functional mode of operation and shall fulfil the requirements of these technical specifications.

6.5 Characteristic of the display

The display shall fulfil all requirements of these technical specifications concerning dimension, displayable colours, resolution, and variation of brilliance.

7. TEST OF THE CHART PRESENTATION, OPERATION AND FUNCTIONALITY

7.1 Preparation of the Equipment Under Test (EUT)

The EUT shall be installed, assembled and connected according to the installation manual. After switching on the test SENC shall be loaded.

7.2 Test of the operation modes

All operating modes as described in the operating manual shall be successively invoked and tested. The requirements of Chapter 4 of this Section shall be fulfilled.

7.3 Test of the displayed features

Whether all features included in the test SENC are visible and correctly displayed shall be tested. For this test, the information density shall be switched to “all features”. The system shall be capable to at least display all features according to the Presentation Standard for Inland ECDIS (Section 3 of these technical specifications). Additionally other user-selectable symbol sets are allowed.

If symbols that deviate from the Inland ECDIS Presentation Library are used for the presentation of any chart information, then they shall:

- be legible;
- be certain and unambiguous in their meaning;
- be of sufficient size to support the nominal viewing distance.

Symbols added to the ECDIS Presentation Library shall not be confused with Presentation Library symbols.

7.4 Test of the scale dependent information density (SCAMIN)

- (a) Whether the SCAMIN functionality (the minimum scale at which the feature may be used for ECDIS presentation) is installed correctly shall be tested.
- (b) For this test, the range shall be used at which the feature shall be visible according to its SCAMIN enumeration (refer to the Inland ENC Feature Catalogue~~IHO-S-57 Attribute Catalogue~~ and the IHO-S-52 Users Manual to the Presentation Library, Chapter 8.4).

7.5 Test of brilliance variation

The Inland ECDIS equipment shall be operated in a dark room and the brilliance shall be brought to its lowest level. The brilliance of the features shall not exceed a value of 15 cd/m², and the background a value of 0,5 cd/m².

7.6 Test of the colours

All user selectable S-52 colour tables shall be sequentially tested to conform to these technical specifications.

7.7 Test of the measurement functions

- (a) All numeric displayed values of the electronic bearing line (EBL) and the variable range marker (VRM) shall exactly match with the analogue positions of the EBL and the VRM (or correspond with the cursor co-ordinates).
- (b) The resolution and increments of the numerical display shall be identical with the analogue values of EBL and VRM.

7.8 Test of the chart update function

Before and after each test step the version numbers of the loaded SENCs and updates shall be recalled as described in the operation manual and showed on the display.

- Step 1: Loading of the test SENC,
- Step 2: Update of the test SENC,
- Step 3: Test of the roll-back function,
- Step 4: Loading of a new SENC.

After an update it shall be possible to recall and display all concerned features.

7.9 Test of displayed features in more than one cell ~~of the same usage~~ for the same area

- (a) It shall be tested whether all features included in the test SENC and in the additional overlay test SENC are visible and correctly displayed. For this test the information density shall be switched to “all features”.
- (b) It shall be tested whether it is possible to select one or more specific cells for presentation if there are several cells from different producers for the same area with the same usage.

8. TEST OF RADAR PICTURE PRESENTATION AND OPERATION

8.1 Preparations

- (a) For the test purposes, the manufacturer or provider shall provide a serial interface at the system to be approved (*Equipment under test* - EUT) which delivers the same actual values (as NMEA 01/83 strings) of position and heading that are used to position and orient the chart.
- (b) During the test, a reference system shall be used of which position and heading values are compared with those of the EUT.
- (c) The EUT shall be connected to any type approved radar equipment (to the choice of the provider).

- (d) The radar picture shall be adjusted in range and bearing with reference to the heading line.

8.2 Test of the radar picture without under laid chart

- (a) If the Inland ECDIS equipment displays the radar picture but the radar operation control remains at the radar equipment (Section 4B, figures 2 and 3), the radar picture of the inland ECDIS equipment shall be considered as the "daughter display" of an item of radar equipment. In that case, the radar picture shall fulfil the display and picture-relevant requirements of the requirements for radar and rate-of-turn indicators.
- (b) If the EUT is a radar installation with integrated Inland ECDIS functionality (Section 4B, figure 4), all requirements of the standards for radar equipment and rate-of-turn indicators shall be fulfilled.

8.3 Test of the radar picture, overlaid information from other vessels and the underlying chart

The Inland ECDIS equipment shall be installed in a reference environment. This can be real (on a ship) or simulated. Position and orientation information of other vessels (according to the Inland AIS technical specifications) shall be applied with several information ages.

8.3.1 Test of the radar overlay

- (a) The radar image shall not be degraded by the chart picture (refer to Chapter 4.3.c of this Section).
- (b) The overlay of information regarding the position and orientation of other vessels shall be only displayed when:
- the information is up-to-date (nearly real-time) and
 - ~~the age of the information does not exceed 5 seconds~~
 - The age of information does not exceed the maximum time out values provided in the table in 5.1 (e) of section 1, Performance Standard for Inland ECDIS. The symbols shall be marked as outdated, if the age of the information exceeds 30 seconds for moving vessels. The position information of the own vessel shall not be displayed, if it is received from a repeater station.
- (c) The overlay of information derived from tracking and tracing devices regarding the position and orientation of other vessels shall be faded out at a user-definable range.
- (d) The position and the orientation of other vessels by
- a directed triangle or
 - a true outline (to scale)

shall be displayed only when the heading of these other vessels is available. For all other vessels a generic symbol shall be used (a square is recommended, a circle shall be used for inland applications only).

- (e) It shall be possible to switch off the chart and any other information layer and to display only the radar picture by one easily accessible control element or menu area.
- (f) The chart picture shall be renewed not later than the radar picture.

8.3.2 *Test of the chart positioning and orientation*

- (a) The static offset of the chart position shall be less than ± 5 m in all ranges up to 2,000 m.
- (b) The static azimuth orientation offset error between radar and chart image shall be less than $\pm 0,5$ deg.
- (c) The correction of these parameters shall be demonstrated in the service mode.
- (d) The dynamic deviation of the chart orientation at rates of turn less than ± 60 deg./min shall be less than ± 3 deg.
- (e) These tests shall be performed visually or by evaluation of measured data.

8.3.3 *Test of scale conformity*

The chart's information shall be compared with well-known reference points contained in the radar picture in order to test whether the chart scale sufficiently conforms to the radar scale.

9. TEST OF ALARMS AND INDICATIONS

- (a) The alarms generated from Inland ECDIS equipment itself as well as the passed alarms delivered by the connected sensors to the ECDIS shall be tested.
- (b) The test procedure shall comprise the following situations:
 - any error in the Inland ECDIS equipment (built-in test equipment - BITE),
 - missing positioning signal,
 - missing radar signal,
 - missing rate of turn signal,
 - missing heading signal,
 - radar map matching not possible,

10. TEST OF FALL BACK ARRANGEMENTS

- (a) This test shall demonstrate the reaction of the Inland ECDIS equipment to a failure of any internal or external component and the possible and required actions by the operator.
- (b) In addition, the operating manual shall be checked to determine whether the measures required by the operator are described adequately and appropriately.

SECTION 4A: MEASURES TO ENSURE SOFTWARE QUALITY

1. GENERAL REQUIREMENTS

Software used in **navigation mode** is a safety-relevant part of a navigation system. Providers of navigation systems shall make sure that all software components used in **navigation mode** allow safe navigation in every situation.

1.1 Software design requirements

Software components shall be clearly designed by means of established software design methods. The design specification shall indicate how safety requirements are addressed in the software design.

A software style guide shall be provided that specifies code writing style, documentation style, modularization, conflict analyses and testing of software components. For every software component documents describing specification and design are required.

1.2 Implementation requirements

Implementation of software modules shall be done by qualified developers, fully understanding the design and safety requirements.

If more than one developer is working on the navigation system software, a version control system shall be used that guarantees conflict-free development.

The implementation shall be according to the design specification and shall reflect the software style guide. Moreover, well known implementation problems (depending on the language used) shall be addressed in the implementation. This includes but is not restricted to:

- null pointer handling,
- uninitialised variables,
- range checking,
- array size verification,
- memory allocation and de-allocation,
- exception handling.

If parallel processing is used (e.g. multiple threads, tasks or processes) problems of conflict-free processing shall be addressed in the implementation. This includes but is not restricted to:

- race conditions,
- re-entrance problems,

- priority inversion,
- deadlocks.

1.3 Test requirements

In accordance with the design specification, software modules shall be tested. The test results shall be compared with the design guidelines and documented in test reports.

Tests shall incorporate module as well as system tests. Providers of a navigation system shall use extensive simulator-based tests to ensure stability of their system. The simulator shall allow the simulation of a complete navigation environment including all required external sensors.

1.4 Third party components requirements

Third party components [OEM (original equipment manufacturer) products] include software not developed by the navigation system provider. This includes but is not restricted to

- static or dynamic linked libraries,
- computer aided design and engineering tools producing source or object code,
- operating systems.

Third party software components shall be chosen according to the general safety requirements. The navigation system provider shall prove that third party components meet the high standards necessary for safe navigation either by providing acceptable quality certificates or by extensive and provable testing of the components.

1.5 Requirements for additional services in navigation mode

Navigation systems may support additional services in **navigation mode** if they are useful. These services shall not interfere with **navigation mode**.

The navigation system provider is responsible for additional test equipment, necessary to verify interface specification, protocol specification and compliance tests with the Inland ECDIS technical specifications.

1.6 Language

Additional national versions of a type-approved Inland ECDIS shall reapply for type approval to be checked for the translation of the user interface.

1.7 Documentation requirements for users

The documentation (manuals) shall contain comprehensive information on installation, operation and service of the navigation system. The presentation of user-relevant information shall be made clear, understandable and without unnecessary technical terms. The user manual shall be available in English, French, German and Dutch. The technical documentation may be made available in English only.

2. METHODS OF TESTING AND REQUIRED RESULTS

2.1 Navigation mode operation test

2.1.1 Performance requirements

The navigation system shall make reliable estimations of position and heading. Moreover, the estimations of position and heading shall be checked by the system for conformity with the required accuracy.

Position and heading information shall be calculated and displayed for the same reference position. This should normally be the centre of the radar antenna. A new position estimate shall at least be available with every revolution of the radar antenna.

2.1.1.1 Position

The navigation system shall estimate and display the position of the ship. The following minimal requirements shall be fulfilled under normal operation conditions:

- (a) The average position estimation shall not deviate more than 5 meters from the true position and shall cover all systematic errors.
- (b) The standard deviation σ shall be less than 5 meters and shall be based on random errors only.
- (c) The system shall be capable to detect deviations of more than 3σ within 30 seconds.

These results shall be verified by a realistic test of at least 60 min.

2.1.1.2 Heading

The navigation system shall estimate and display the heading of the ship. The following minimal requirements shall be fulfilled:

- (a) The average heading angle estimation shall not deviate more than 1 degree from the radar heading direction and shall cover all systematic errors. The offset between ship heading direction and radar heading shall be less than 1 degree.
- (b) The standard deviation σ shall be less than 2 degrees and shall be only based on random errors.

These results shall be verified by a realistic test of at least 60 min.

2.1.2 Sensor failure

The navigation system shall check proper operation of the position and heading estimation online. Problems shall to be detected within 30 seconds. In case of malfunction, the navigation system shall inform the user about the problem and its consequence for navigation.

If a critical sensor alarm signalizes, that position or heading does not meet the required accuracy, reliable navigation is not possible the navigation chart must be switched off~~shall not be displayed~~.

2.1.3 Performance test interface

A navigation system provider shall equip navigation systems during the compliance test with a standard NMEA interface sending the position and heading information used by the navigation system. This information shall be encoded by NMEA sentences known as GGA and HDTPAT. Additional sentences like RMC, ROT and VTG are accepted.

Example: ~~GGA - Global Position System Fix Data~~

~~\$GPGGA,123519,4807.038,N,01131.324,E,1,08,0.9,545.4,M,46.9,M, , *42<CR><LF>~~

123519	Fix taken at 12:35:19 UTC. (This field has to provide the time of the position estimation.)
4807.038,N	Latitude 48 deg 07.038' N (This field has to provide the latitude of the fix.)
01131.324,E	Longitude 11 deg 31.324' E (This field has to provide the longitude of the fix.)
1	Fix quality (0 = invalid, 1 = GPS fix, 2 = DGPS fix (This field can have any valid value.)
08	Number of satellites being tracked. (This field can have any valid value.)
0.9	Horizontal dilution of position (This field can have any valid value.)
545.4,M	Altitude, Metres, above mean sea level. (This field is can have any valid value.)
46.9,M	Height of geoids (mean sea level) above WGS 84 ellipsoid. (This field can have any valid value.)
(empty field)	Time in seconds since last DGPS update. (This field can have any valid value.)
(empty field)	DGPS station ID number. (This field can have any valid value.)

Example: ~~PAT - Position and altitude message~~
~~(Ashtech proprietary position and altitude message.)~~

~~\$GPPAT,223924.0,3922.2871,N,12159.4503,W,+/-00253.2,121.673,+/-002.59,+/-004.61,.....
 ...0.0031,0.0205,0<CR><LF>~~

223924.0	UTC of position. (This field has to provide the time of the position estimation.)
3922.2871,N	Latitude 39 deg 22.2871' N (This field has to provide the Latitude of the fix.)
12159.4503,W	Longitude 121 deg 59.4503' W (This field has to provide the Longitude of the fix.)
+/-00253.2	Altitude in meters. (This field can have any valid value.)
121.673	Heading in degrees. (This field has to provide the heading angle use by the navigation system.)
+/-002.59	Pitch in degrees. (This field can have any valid value.)

+/-004.61	Roll in degrees. (This field can have any valid value.)
0.0031	Attitude phase measurement error MRMS (meters). (This field can have any valid value.)
0.0205	Attitude baseline length rms error, BRMS (meters). (This field can have any valid value.)
0	Attitude reset flag ((0: good attitude, 1: rough estimate or bad attitude). (This field can have any valid value.)

~~These Both~~ strings shall be sent ~~over the same NMEA interface preferably every 0.1 second,~~ at least every second. ~~The P~~ position and heading shall be according to the definitions in Chapter 2.1.1.1 and Chapter 2.1.1.2 of this Section.

2.2 General software tests

2.2.1 Equipment documentation

The following documents shall be provided for admittance and shall be shipped with every navigation system:

- Users manual,
- Installation manual,
- Service manual.

The following documents and files shall be provided during the admittance procedure and are not required for end users:

- design specification,
- software style guide,
- certificates of third party software components or test and simulation protocols.

The documents and files provided shall allow for a complete verification of compliance with the Inland ECDIS technical specifications.

2.2.2 Endurance test

The navigation system shall pass an endurance test of 48 hours of uninterrupted operation under normal operation conditions. The system shall provide standard interfaces for performance and resource monitoring during operation. Monitoring the system shall show no indication of system instability, memory leaking or any kind of performance loss over time. Navigation systems supporting additional services while running in **navigation mode** shall provide the necessary test equipment including all documents mentioned in Chapter 1.7 of this Section.

3. CHANGES TO CERTIFIED SYSTEMS

3.1 General requirements

Navigation systems installed on board shall be functionally equivalent to a system certified by authorities. For every system the navigation system provider shall ship a statement of compliance with the Inland ECDIS technical specifications and its functional equivalence to the certified system.

The competent authority is entitled to check Inland ECDIS compliance of installed systems at any time.

3.2 Hardware and software changes

The navigation system provider can change software or hardware as long as Inland ECDIS compliance is maintained. Changes shall be fully documented and submitted to the competent authority together with an explanation of how the navigation system is affected by these changes. The competent authority can require a partial or complete renewal of certification if considered necessary. The aforementioned also applies to the use of an approved Inland ECDIS with another national version of the operating system.

The following changes do not affect certification of the system and require only a notice to the competent authority:

- minor changes on third party components (e.g. operation system or library updates),
- use of equivalent or better hardware components (e.g. faster microprocessor, newer chip revisions, equivalent graphic card etc.),
- minor changes in source code or documentation.

SECTION 4B: SYSTEM CONFIGURATIONS (FIGURES)

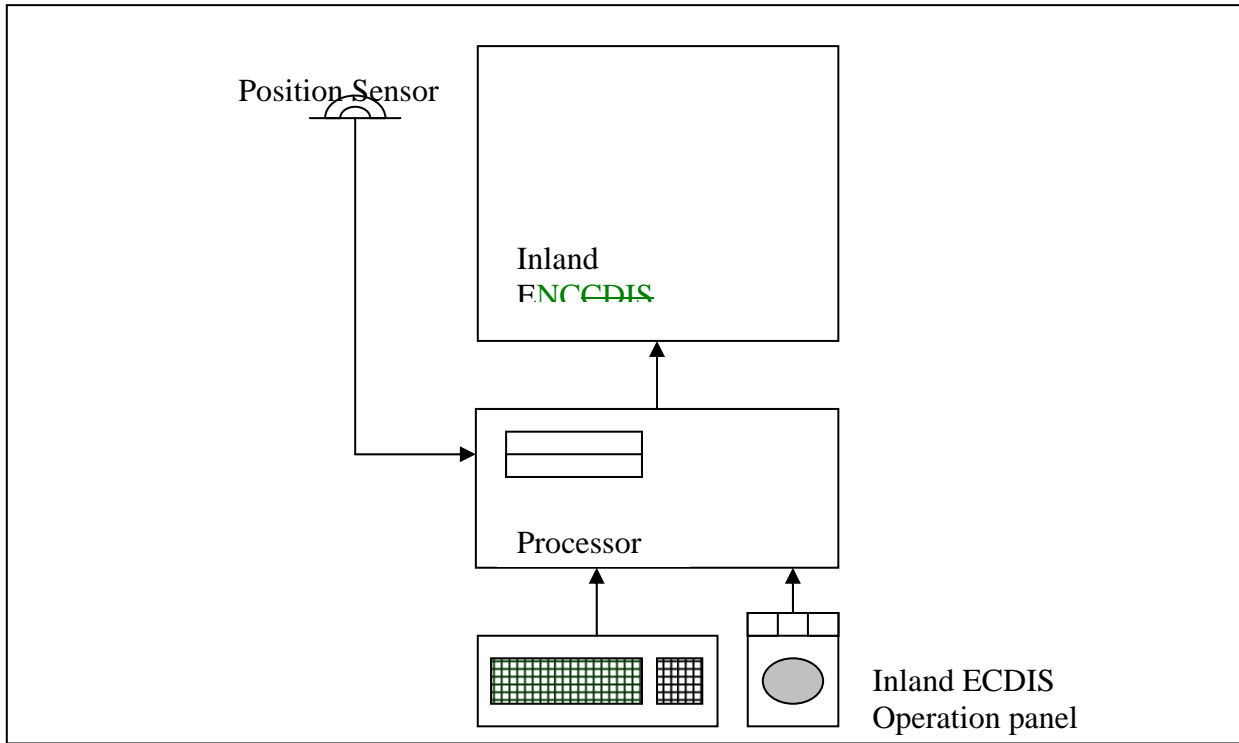

Fig. 1: Inland ECDIS equipment, self-sufficient system without connection to radar

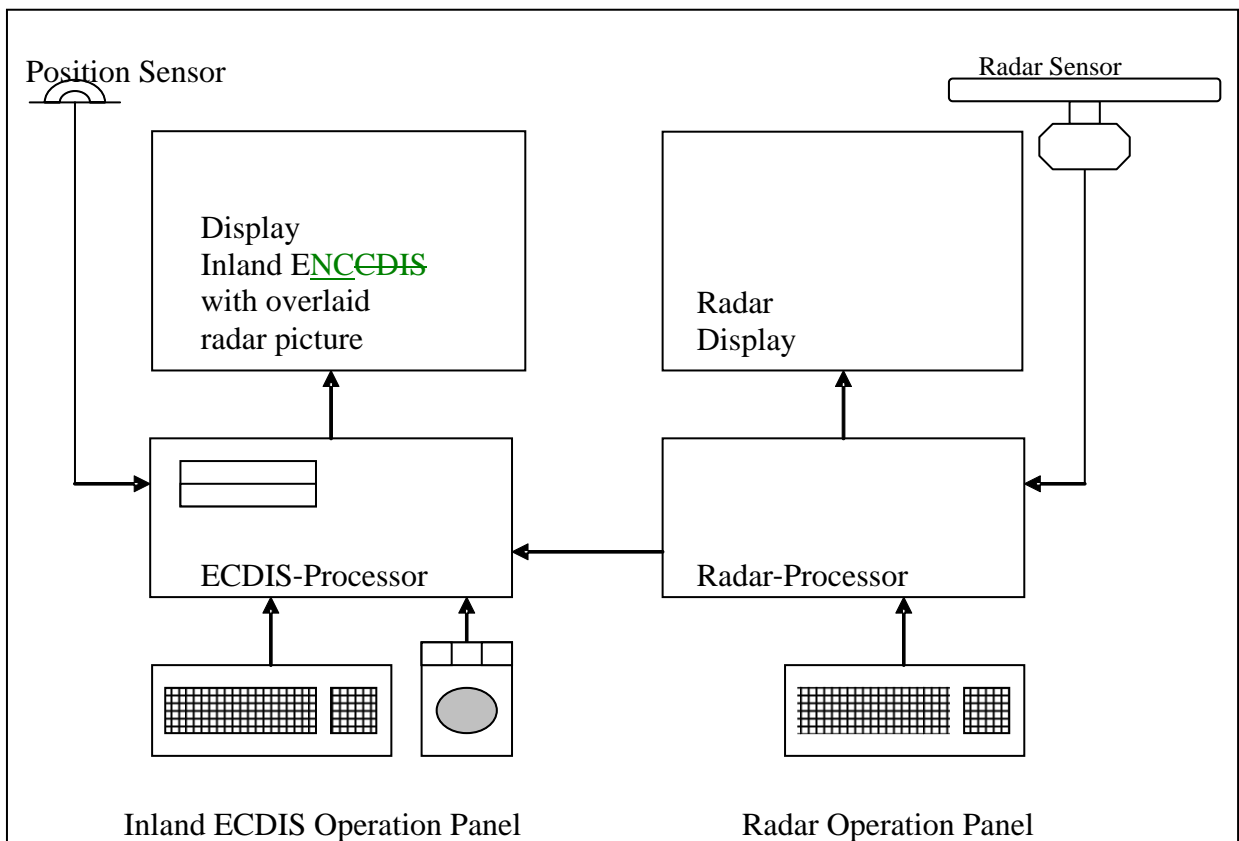

Fig. 2: Inland ECDIS equipment, self-sufficient system with connection to radar

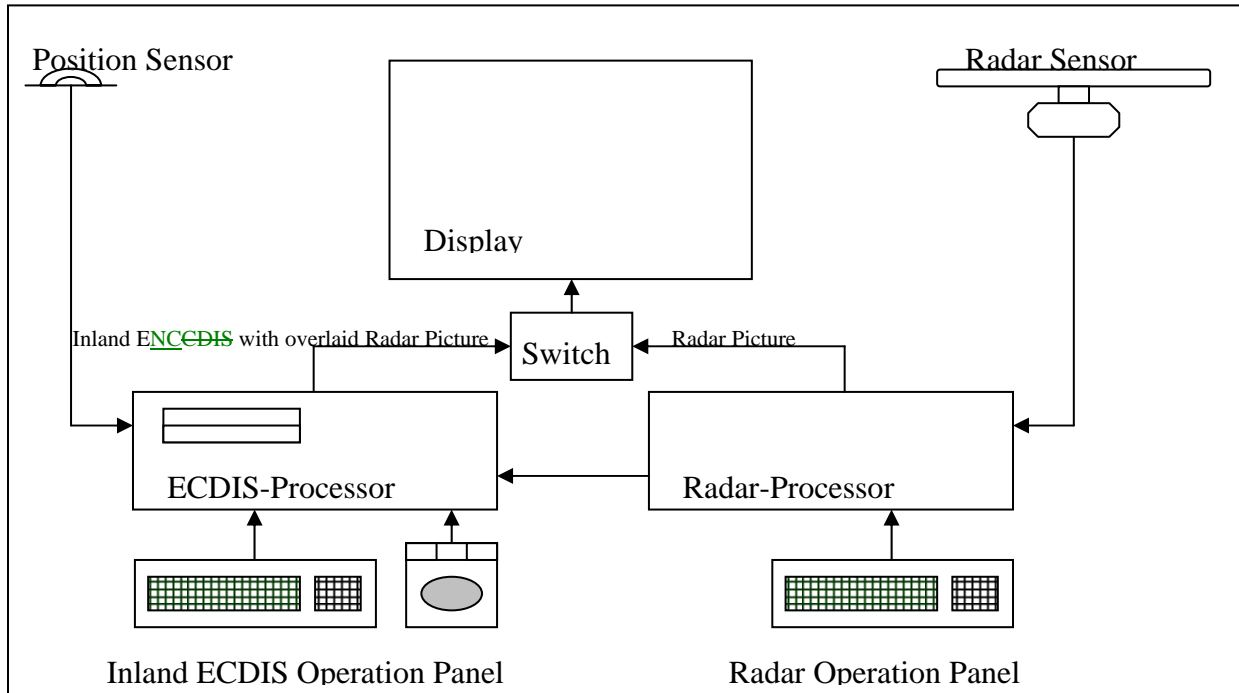

Fig. 3: Inland ECDIS equipment with connection to radar and shared monitor

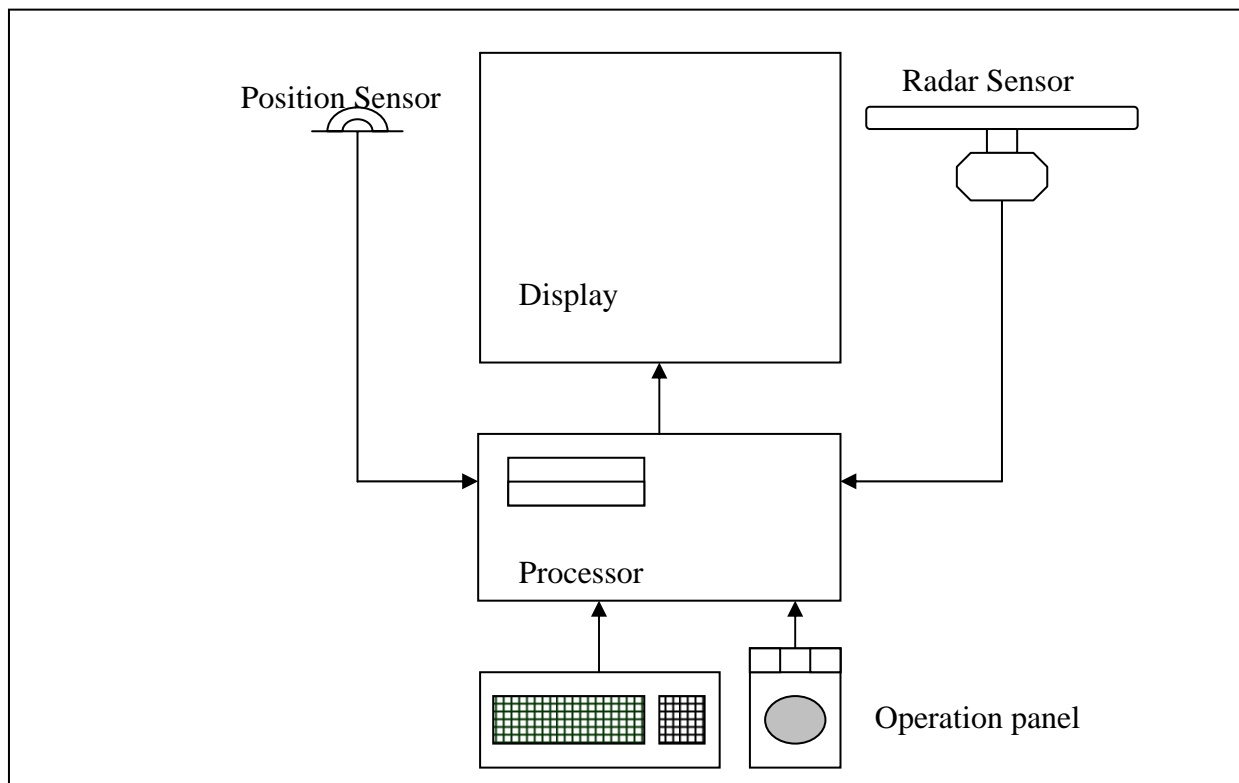

Fig. 4: Navigational radar equipment with integrated Inland ECDIS functionality

SECTION 5: GLOSSARY OF TERMS

Sources

1. IMO Resolution [MSC.232\(82\)A-817\(19\)](#)
2. IHO S-52 [and IHO S-32](#) (~~especially~~ Appendix ~~13~~ “Glossary of ECDIS-related Terms”)
3. IHO S-57 (especially Part 1 “General Introduction”, clause 5 “Definitions”)
4. Technical Specifications for Inland ECDIS
 - 4.1 Section 1: Performance Standard for Inland ECDIS
 - 4.2 Section 2: Data Standard for Inland ENC’s
 - 4.3 Section 2a: Codes for Producers and Waterways
 - 4.4 Section 3: Presentation Standard for Inland ECDIS
 - 4.5 Section 4: Operational and Performance Requirements, Methods of Testing and Required Tests Results including its Sections 4A and 4B
5. IENC [Domain in the S-100 Registry Register](#)
6. IEHG Product Specification for Inland ENC’s
7. IEHG Inland ENC Feature Catalogue
8. IEC Guideline [61174 Edition 3.0](#)
9. [Annex IX, Parts III to VI, of EU-Directive 2006/87: Requirements applicable to radar installations and rate-of-turn indicators](#)~~CCNR / ZKR Radar Regulations~~
10. [Commission Regulation \(EC\) No 414/2007 concerning the technical guidelines for the planning, implementation and operational use of river information services \(RIS\)](#)~~CCNR / ZKR RIS Guidelines 2004~~

Definitions of the features and attributes can be derived from

~~the tables of IHO S-57, Appendix A “Object Catalogue”, and~~

the Feature Catalogue for Inland ENC’s (Appendix 1.1 to these technical specifications)

Term or Abbreviation	Definition	Source
----------------------	------------	--------

Acronym	6-character-code of the feature/of the attribute	3
---------	--	---

Term or Abbreviation	Definition	Source
AIS	Automatic Identification System: An automatic communication and identification system intended to improve the safety of navigation by assisting in the efficient operation of vessel traffic services (VTS), ship reporting, ship-to-ship and ship-to-shore operations.	2
All information density	All information density (all display) means the maximum amount of SENC information. Here, in addition to the standard display, also all other objects are displayed, individually on demand.	4.1
Attribute	A defined characteristic of an entity (e.g. the category of a light, the sector limits, the light characteristics etc.).	3
Attribute copied	S-57/S-100 attributes (with their complete list of attribute values) which were extended according to the requirements of Inland ECDIS. All new attributes have the same name like their source, but written in small case letters.	7
CCNR / ZKR	<p>Central Commission for Navigation on the Rhine; international commission based on the “Convention of Mannheim”. Current Member States are Belgium, France, Germany, The Netherlands and Switzerland. The most important and permanent objectives of CCNR are:</p> <p>Prosperity of inland navigation on the Rhine and in Europe</p> <p>Maintenance of the high level of safety in inland navigation and its surroundings</p>	
Cell (chart cell)	A cell is a geographical area containing Inland ENC data.	3
CIE colour calibration	Procedure to confirm that the colour specified in IHO S-52 is correctly reproduced on the ECDIS display.	2
Collection feature	Type of feature containing information about the relationships between other features.	3
Compilation scale	The scale with which the chart information meets the IHO requirements for chart accuracy. It is established by the producing Hydrographic office and encoded in the ENC.	6
Datum	A set of parameters specifying the reference surface or the reference coordinate system used for geodetic control in the calculation of coordinates of points on the earth. Commonly datums are defined as horizontal and vertical datums separately. For the practical use of the datum it is necessary to have one or more well distinctive points with coordinates given in that datum.	2
Datum, horizontal	A set of parameters specifying the reference for horizontal geodetic control, commonly the dimensions and the location of a reference ellipsoid. (The horizontal datum must be WGS 84.)	6
Datum, vertical	A surface to which elevations and/or depths (soundings and tide heights) are referred. For elevations commonly a level (equipotential) surface, approximately the mean sea level is used, for depths in many cases low water.	6

Term or Abbreviation	Definition	Source
Differential GPS (DGPS)	A form of GPS in which the reliability and accuracy are enhanced by broadcasting a time-varying correction message from a GPS monitoring receiver (differential mode) at a known position on shore. The corrections are fed automatically into the GPS receiver onboard and used to compute an improved position.	4
Display base	Minimum information density; means the minimum amount of SENC information that is presented and which cannot be reduced by the operator, consisting of information that is required at all times in all geographic areas and under all circumstances.	1
Display scale	The ratio between a distance on the display and a distance on the ground, normalised and expressed as a ratio, e.g. 1:10 000.	2
EBL	Electronic Bearing Line	4.5
ECDIS	Electronic Chart Display and Information System (ECDIS) means a navigation information system which with adequate back-up arrangements can be accepted as complying with the up-to-date chart required by regulations V/19 and V/27 of the 1974 SOLAS Convention, as amended, by displaying selected information from a system electronic navigational chart (SENC) with positional information from navigation sensors to assist the mariner in route planning and route monitoring, and if required display additional navigation-related information. Electronic Chart Display and Information System; A navigation information system which can be accepted as complying with the up to date chart required by regulation V/20 of the 1974 SOLAS Convention, by displaying selected information from a system electronic navigational chart (SENC) with positional information from navigation sensors to assist the mariner in route planning and route monitoring, and if required display additional navigation related information. The performance requirements for ECDIS are defined in the Performance Standard for ECDIS developed by IMO/IHO HGE (Harmonized Group on ECDIS).	1
Edge	A one-dimensional spatial object, located by two or more coordinate pairs (or two connected nodes) and optional interpolation parameters.	3
Electronic chart	Very broad term to describe the data, the software, and the electronic system, capable of displaying chart information. An electronic chart may or may not be equivalent to the paper chart required by SOLAS.	2
ENC	Electronic Navigational Chart; The data base, standardized as to content, structure and format, issued for use with ECDIS on the authority of government authorized hydrographic offices. The ENC contains all the chart information necessary for safe navigation and may contain supplementary information in addition to that contained in the paper chart (e.g. sailing directions) which may be considered necessary for safe navigation.	1
ENC cell	The geographic division of ENC data for distributing purposes.	8
Enumeration	A specific quality or quantity assigned to an attribute (e.g. "leading light", the limiting angles, the code specifying the light's colour – see attribute).	7
Exchange format	A specification for the structure and organization of data to facilitate exchange between computer systems.	2

Term or Abbreviation	Definition	Source
Exchange set	Set of files representing a complete, single purpose (i.e. product specific) data transfer. For example, the ENC product specification defines an exchange set which contains one catalogue file and at least one data set file.	2
Feature	<p>An identifiable set of information. A feature may have attributes and may be related to other features.</p> <p>A digital representation of all or a part of an entity by its characteristics (attributes), its geometry, and (optionally) its relationships to other features (e.g., the digital description of a light sector specifying, amongst others, sector limits, the colour of the light, the visibility range, etc., and a link to a light tower, if any).</p>	2
Feature catalogue	The comprehensive list of currently identified features, attributes and enumerations which are allowed for the use in Inland ENCs.	7
Feature copied	S-57 features (with their complete set of attributes) which were extended according to the requirements of Inland ECDIS. All new features have the same name like their source, but are written in small case letters.	7
Feature Data Dictionary	<p>A feature data dictionary specifies independent sets of features and attributes that may be used to describe geographic information in a particular context.</p> <p>A feature data dictionary may be used to develop a feature catalogue.</p>	
File	An identified set of S-57 records collected together for a specific purpose. The file content and structure must be defined by a product specification.	2
Geo Feature	Type of feature containing the descriptive characteristics of a real world entity.	2
Geometric Primitive	One of three basic geometric units of representation: point, line and area.	2
Heading	The direction in which the longitudinal axis of a craft is pointed, usually expressed as an angular distance from north clockwise through 360 degrees (true, magnetic or compass).	2
Head-up display	The information shown on the display (radar or ECDIS) is directed so that the vessel's heading is always pointing upward. This orientation corresponds to the visual view from the bridge in direction of the ship's heading. This orientation may require frequent rotations of the display contents. Changing the ship's course, or yawing of the vessel may render this unstabilized orientation mode unreadable.	2
IEC	International Electrotechnical Commission: An international (non-governmental) organization which produces world standards for electrical and electronical engineering with the objective of facilitating international trade.	2

Term or Abbreviation	Definition	Source
IHO	International Hydrographic Organization: Coordinates the activities of national hydrographic offices; promotes standards and provides advice to developing countries in the fields of hydrographic surveying and production of nautical charts and publications.	2
IHO registry	<p>IHO Geospatial Information Infrastructure Registry. A registry is the information system on which a register is maintained. In the case of S-100 IHO hosts a registry that provides a facility to store various registers of hydrographic-related information. A “registry” is the entire information system (or location) in which a collection of registers is located.</p> <p>In the case of the future S-57 (the so-called S-100) IHO will host a registry that will provide a facility to store various registers of hydrographic-related information.</p> <p>This will include feature data dictionaries, metadata and code lists (e.g. sounding datums).</p> <p>There will be registers for Hydrographic Information, Dynamic Ice Coverage, Additional Military Layers (AMLs), and Inland ENC.</p> <p>Other types of information that do not fit into these categories can be included in the Open ECDIS Forum (OEF) register. For each register there is an organization that will be responsible for its content and management.</p>	5
(IHO-) S-32, App. 1	Hydrographic Dictionary - Glossary of ECDIS Related Terms.	2
(IHO-) S-52	Specifications for chart content and display aspects of ECDIS.	2
(IHO-) S-52, App. 1	Guidance on updating the Electronic Navigational Chart	2
(IHO-) S-52, App. 2	Colour and symbols specifications for ECDIS.	2
(IHO-) S-57	IHO Transfer standard for digital hydrographic data.	3
(IHO-) S-57, App. A	IHO Object Catalogue.	3
(IHO-) S-57, App. B	ENC Product Specifications.	3
(IHO-) S-62	ENC Producer Codes	
IMO	International Maritime Organization: Formerly called IMCO, the IMO is the specialized agency of the United Nations responsible for maritime safety, efficiency of navigation and prevention of marine pollution from ships.	2

Term or Abbreviation	Definition	Source
Information Mode	means the use of the Inland ECDIS for information purposes only without overlaid radar image.	4.1
Inland AIS	AIS for the use in inland navigation and interoperable with (maritime) AIS – technically enabled by amendments and extensions to the (maritime) AIS	
Inland ECDIS	An Electronic Chart Display and Information System for inland navigation, displaying selected information from a Inland System Electronic Navigational Chart (Inland SENC) and optionally, information from other navigation sensors.	4.1
Inland ENC (IENC)	Inland Electronic Navigational Chart (IENC) means the database, standardized as to content, structure and format, for use with inland electronic chart display and/ or information systems operated onboard of vessels transiting inland waterways. An IENC is issued by or on the authority of a competent government agency, and conforms to standards initially developed by the International Hydrographic Organization (IHO) and refined by the Inland ENC Harmonization Group. An IENC contains all the chart information necessary for safe navigation on inland waterways and may contain supplementary information in addition to that contained in the paper chart (e.g. sailing directions, machine-readable operating schedules, etc) which may be considered necessary for safe navigation and voyage planning. Inland Electronic Navigational Chart: The database, standardised as to content, structure and format, issued for use with Inland ECDIS. The Inland ENC complies to the IHO standards S-57, S-62 and S-52, enhanced by the additions and clarifications of this standard for Inland ECDIS. The Inland ENC contains all essential chart information and may also contain supplementary information that may be considered as helpful for navigation.	4.1
Inland ENC register/domain	Domain within the IHO Geospatial Information Infrastructure Registry dedicated for Inland ENC – related entries. Register within the registry of IHO dedicated for Inland ENC – related entries.	5
Inland SENC	Inland System Electronic Navigational Chart: A database resulting from the transformation of the Inland ENC by Inland ECDIS for appropriate use, updates to the Inland ENC by appropriate means and other data added by the mariner. It is this database that is actually accessed by the Inland ECDIS for the display generation and other navigational functions. The Inland SENC may also contain information from other sources.	4.1
INT 1	International chart 1: Specification of symbols, abbreviations and terms to be used in the International Chart Series of IHO. (Provides the chart user with a key to symbols, abbreviations and terms used on charts compiled in accordance with the "Chart Specifications of the IHO"). Contains description entries for features and attributes. Can be seen as the reference to the legend of paper charts.	2
Integrated display	means a head-up, relative-motion picture consisting of the Inland SENC overlaid with the radar-image with matching scale, offset and orientation.	4.1
Look-up table	A table giving symbology instructions to link SENC objects to point, line or area symbolisation and providing display priority, radar priority, IMO category and optional viewing group.	2

Term or Abbreviation	Definition	Source
M-4	Gives chart specifications of the IHO for compiling nautical charts, together with agreed symbols and abbreviations adopted for general use by Member States. Provides also regulations for INT Charts. Contains description entries for features and attributes.	3
Meta object	A feature which contains information about other features.	2
Navigation mode	means the use of the Inland ECDIS for conning the vessel with overlaid radar image.	4.1
North-up display	Information shown on the display (radar or ECDIS) with the north direction upward.	2
Other navigational information	Navigational Information not contained in the SENC, that may be displayed by an ECDIS, such a radar information.	2
Overscale	Displaying data at a larger scale than it was compiled for.	2
Own-ship	The term which identifies the vessel upon which an ECDIS is operating.	2
Own ship's safety contour	The contour related to the own ship selected by the mariner from the contours provided for in the SENC, to be used by ECDIS to distinguish on the display between the safe and the unsafe water, and for generating anti-grounding alarms.	2
Performance standard for ECDIS	Standard developed under the authority of IMO to describe the minimum performance requirements for navigational devices and other fittings required by the SOLAS Convention. Adopted by IMO on 5 December 2006 23 November 1995 as Assembly resolution and published as MSC.232(82), Annex to IMO Resolution A19/Res 817 (15 December 1995).	2
Pick report (feature report)	The result of querying a displayed point-symbol, line or area for further information from the data base which is not represented by the symbol.	2
Presentation library for ECDIS	A set of mostly digital specifications, composed of symbol libraries, colour schemes, look-up tables and rules, linking every feature and attribute of the SENC to the appropriate presentation of the ECDIS display. Published by IHO as Annex A Appendix 2 of its Special Publication No. 52 (S-52).	2
Product specification	A defined subset of the entire specification combined with rules, tailored to the intended usage of the transfer data. (The ENC Product specification specifies the content, structure and other mandatory aspects of an ENC.)	2

Term or Abbreviation	Definition	Source
(Radar) range	Distance from the radar antenna. For inland navigation the radar range has to be sequential switchable according to the CCNR Radar Regulations.	9
Relative motion display	A relative motion display shows the chart information and radar targets moving relative to the vessel position fixed on the screen.	2
Route planning	An ECDIS function in which the area is displayed which is needed to study the intended route, to select the intended track, and to mark the track, its way points and navigational notes.	1
SCAMIN	The minimum scale at which the feature may be used e.g. for ECDIS presentation.	3
SENC	System Electronic Navigational Chart: A data base resulting from the transformation of the ENC by ECDIS for appropriate use, updates to the ENC by appropriate means and other data added by the mariner. It is this data base that is actually accessed by the ECDIS for the display generation and other navigational functions. The SENC may also contain information from other sources.	2
Spatial object	An object which contains locational information about real world entities.	2
Standard display	Standard Information Density means the default amount of SENC information that shall be visible when the chart is first displayed on ECDIS.	4.1
[Vessel] Tracking and Tracing	The function of maintaining status information of the vessel and – if needed – combined with information on cargo and consignments [tracking] and the retrieving of information concerning the whereabouts of the vessel and – if needed – combined with information on cargo, consignments and equipment [tracing].	10
True motion display	A display in which the own vessel and each radar target moves with its own true motion, while the position of all charted information remains fixed.	2
User-defined settings	Means the possibility to use and store a profile of display and operation controls-settings.	4.1
VRM	V ariable R ange M arker.	4.5
WGS 84	WORLD GEODETIC SYSTEM: The geodetic basis for the „ N avigational S atellite T iming and R anging - G lobal P ositioning S ystem“ (NAVSTAR-GPS), which enables the surveying of the earth and its entities and was developed by the United States Department of Defence. This global geodetic reference system is recommended by IHO for hydrographic and cartographic use.	6